

GENERAL NOTES:

- VISITS TO THE JOB SITE BY REPRESENTATIVES OF THE ENGINEER DO NOT SUBSTITUTE APPROVAL OF THE WORK PERFORMED BY THE CONTRACTOR OR HIS SUBCONTRACTORS AND ARE MERELY FOR THE PURPOSE OF OBSERVING THE WORK PERFORMED.
- CONTRACTOR SHALL NOTIFY ENGINEER/ARCHITECT OF ANY DISCREPANCIES, OMISSIONS OR CONFLICTS BETWEEN THE VARIOUS ELEMENTS OF THE WORKING DRAWINGS AND/OR SPECIFICATIONS BEFORE PROCEEDING WITH ANY WORK INVOLVED. IN ALL CASES, UNLESS OTHERWISE DIRECTED, THE MOST STRINGENT REQUIREMENTS SHALL GOVERN AND BE PERFORMED.
- CONTRACTOR SHALL VERIFY ALL CONDITIONS, DIMENSIONS AND ELEVATIONS, ETC., AT THE SITE AND SHALL COORDINATE WORK PERFORMED BY ALL TRADES. DO NOT SCALE DRAWINGS.
- SHOP DRAWINGS SHALL BE REVIEWED BY THE ENGINEER/ARCHITECT PRIOR TO FABRICATION OR ERECTION FOR ANY PREFABRICATED OR MANUFACTURER-DESIGNED COMPONENTS AND SHALL BE STAMPED BY A PROFESSIONAL ENGINEER REGISTERED IN THE STATE WHERE THIS STRUCTURE RESIDES.
- SIZES, LOCATIONS, LOADS, AND ANCHORAGES OF EQUIPMENT SHALL BE VERIFIED IN THE FIELD WITH EQUIPMENT MANUFACTURERS (SUPPLIERS) PRIOR TO FABRICATION OR INSTALLATION OF SUPPORTING STRUCTURES.
- TEMPORARY BRACING SHALL BE PROVIDED WHEREVER NECESSARY TO TAKE CARE OF ALL LOADS TO WHICH THE STRUCTURE MAY BE SUBJECTED, INCLUDING WIND. SUCH BRACING SHALL BE LEFT IN PLACE AS LONG AS MAY BE REQUIRED FOR SAFETY, OR UNTIL ALL THE STRUCTURAL ELEMENTS ARE INSTALLED.
- DURING AND AFTER CONSTRUCTION THE CONTRACTOR AND/OR OWNER SHALL KEEP LOADS ON THE STRUCTURE WITHIN THE LIMITS OF THE DESIGN LOAD.
- CONTRACTOR AND ALL SUBCONTRACTORS SHALL PERFORM THEIR TRADES AND DUTIES IN A MANNER CONFORMING TO THE PROCEDURES AND REQUIREMENTS AS STATED IN THE 2012 INTERNATIONAL RESIDENTIAL CODE, (OR LATEST ACCEPTED CODE ADOPTED BY THE LOCAL BUILDING OFFICIALS).
- ANY SPECIAL INSPECTIONS REQUIRED BY THE BUILDING OFFICIAL OR THE BUILDING CODE ARE THE RESPONSIBILITY OF THE OWNER OR CONTRACTOR.
- CONTRACTOR SHALL BE RESPONSIBLE FOR SAFETY AND PROTECTION WITHIN AND ADJACENT TO THE JOB SITE.

LUMBER NOTES:

- MEMBER GRADES SHALL BE AS FOLLOWS UNLESS OTHERWISE NOTED:
 GLU-LAM BEAMS24F-V4 DF/DF
 JOISTSDOUG-FIR #2 BTR
 HEADERS.....DOUG-FIR #2 BTR
 POST.....DOUG-FIR #1 BTR
 STUDS NON-BEARING WALLS.....DOUG-FIR STUD GRADE BTR
 STUDS BEARING WALLS.....DOUG-FIR #2 BTR
 PRE-FAB JOISTSAS PER MANUFACTURER
 SILL PLATES IN CONTACT WITH CONCRETE.....DOUG-FIR #2 PRESSURE TREATED FOR MOISTURE PROTECTION
- WHERE NOT NOTED OTHERWISE, CONNECT ALL WOOD TO CONCRETE, WOOD TO STEEL AND WOOD TO WOOD (EXCEPT STUD TO PLATE) WITH SIMPSON CONNECTORS.
- ALL MULTIPLE PLATES AND LEDGERS SHALL BE NAILED TOGETHER WITH 16d NAILS AT 8" ON CENTER.
- STUD WALLS SHALL RUN CONTINUOUS BETWEEN POINTS OF HORIZONTAL SUPPORT. PROVIDE BRACING WHERE OTHERWISE.
- BLOCK ALL HORIZONTAL EDGES OF PLYWOOD WALL SHEATHING WITH 2" NOMINAL BLOCKING. BLOCK EDGES OF PLYWOOD ON FLOORS AND ROOF AS DIRECTED ON DRAWINGS.
- SOLID 2" NOMINAL BLOCKING SHALL BE PROVIDED AT ENDS OR POINTS OF SUPPORT OF ALL WOOD JOISTS.
- ALL LEDGER BOLTS SHALL HAVE PLATE WASHERS WITH A MINIMUM DIA. EQUAL TO 3 TIMES THE BOLT DIA. UNLESS SHOWN OTHERWISE IN DETAILS.
- MINIMUM NAILING SHALL BE AS PER IRC.
- FASTENERS SUCH AS STAPLES, CAN ONLY BE SUBSTITUTED FOR NAILS AT A RATE EQUAL TO LOAD VALUES PROVIDED BY I.C.B.O. APPROVAL. SEE ATTACHED SCHEDULE.
- JOISTS SHALL HAVE BRIDGING, BLOCKING AND NOTCHED BEARING PLATES AS RECOMMENDED BY THE MANUFACTURER WITH A MINIMUM OF ONE ROW OF BRACING AT MID SPAN. MANUFACTURER SHALL SUPPLY AND CONTRACTOR SHALL INSTALL.

FOOTINGS, FOUNDATIONS, AND SLAB ON GRADE NOTES:

- ALL FOOTING SIZES ARE BASED ON AN ASSUMED SOIL BEARING PRESSURE OF 1500 PSF. ANY SOIL CONDITION ENCOUNTERED DURING EXCAVATION THAT IS CONTRARY TO THOSE USED FOR DESIGN OF FOOTINGS AS OUTLINED IN WORKING DRAWINGS SHALL BE BROUGHT TO THE ATTENTION OF THE ARCHITECT/ENGINEER BEFORE PROCEEDING.
- ALL FOOTINGS SHALL BEAR ON UNDISTURBED NATIVE SOIL OR ENGINEERED GRANULAR FILL COMPACTED TO 95% OF MAX. DENSITY, BASED ON ASTM D 1557 METHOD OF COMPACTION. FILL SHALL BE PLACED IN LAYERS NOT TO EXCEED SIX IN. IN DEPTH AFTER COMPACTION AND SHALL EXTEND DOWN TO IN-SITU SOILS. FILL SHALL BE COMPACTED UNDER ALL CONCRETE WORK ON THE SITE.
- NO FOOTINGS SHALL BE PLACED IN WATER, SNOW, FROZEN GROUND, OR UNSTABLE SOILS.
- ALL EXCAVATIONS ADJACENT TO AND BELOW FOOTING ELEVATION FOR OTHER TRADES SHALL BE ACCOMPLISHED PRIOR TO POURING ANY FOOTINGS.
- CONTRACTOR SHALL BE RESPONSIBLE FOR LATERALLY SUPPORTING ALL RETAINING TYPE FOUNDATION WALLS WHILE COMPACTING BEHIND WALLS AND UNTIL ALL SUPPORTING MEMBERS HAVE BEEN PLACED (SUCH AS FLOOR SLABS). ALL OPEN EXCAVATIONS AND TRENCHES SHALL BE SUPPORTED AND BARRICADED BY CONTRACTOR TO CONFORM WITH OSHA SAFETY STANDARDS.
- ALL REINFORCEMENTS SHALL BE SECURELY TIED IN PLACE PRIOR TO POURING CONCRETE.
- PROVIDE DOWELS IN FOOTING AND FOUNDATIONS TO MATCH ALL VERTICAL BARS IN WALLS AND COLUMNS ABOVE, UNLESS NOTED OTHERWISE.
- PROVIDE CONTROL JOINTS (SEE TYPICAL DETAILS) IN SLABS AT A MAX. OF 15 FT. o.c. EACH WAY AND AS SHOWN ON PLANS. POUR SLABS BETWEEN CONTROL JOINTS, SO THAT ADJACENT POURS ARE STAGGERED AT LEAST TWO DAYS APART. SHORTLY AFTER SLABS ARE POURED, MAKE SAW-CUT JOINTS AT A MAX. OF 15 FT. o.c. BETWEEN POUR CONTROL JOINTS.

CONCRETE NOTES:

- ALL COLUMNS AND WALLS AND ALL EXTERIOR FLATWORK, CURBS, GUTTERS, ETC., SHALL BE NORMAL WEIGHT CONCRETE WITH A COMPRESSIVE STRENGTH EQUAL TO AT LEAST 4,000 LBS. PER SQUARE INCH WITHIN 28 DAYS AFTER POURING. THE WATER/CEMENT RATIO SHALL BE NO GREATER THAN 0.44 AND SLUMP SHALL BE 3" OR LESS. MINIMUM CEMENT CONTENT SHALL BE 564 LBS. PER CUBIC YARD.
- ALL FOOTINGS, FOUNDATIONS, AND INTERIOR SLABS ON GRADE SHALL BE NORMAL WEIGHT CONCRETE WITH A COMPRESSIVE STRENGTH EQUAL TO AT LEAST 3,000 LBS. PER SQUARE INCH WITHIN 28 DAYS AFTER POURING. THE WATER/CEMENT RATIO SHALL BE NO GREATER THAN 0.50 AND SLUMP SHALL BE 3" OR LESS. MINIMUM CEMENT CONTENT SHALL BE 470 LBS. PER CUBIC YARD.
- UNLESS OTHERWISE NOTED, ALL CONSTRUCTION JOINTS SHALL BE KEYED WITH A KEY 1-1/2" DEEP, A LENGTH 2" LESS THAN THE MEMBER, AND A WIDTH 1/2 OF THE MEMBER. REINFORCING SHALL BE CONTINUOUS THRU JOINT.
- ALL METAL REINFORCEMENT SHALL BE DEFORMED TYPE BARS AND SHALL CONFORM TO THE REQUIREMENTS OF THE STANDARD SPECIFICATIONS A.S.T.M. A615 GRADE 60. BEAM AND COLUMN TIE REINFORCEMENT SHALL CONFORM TO THE REQUIREMENTS OF THE STANDARD SPECIFICATION A.S.T.M. A615 GRADE 60.
- ALL SPLICES IN CONTINUOUS CONCRETE REINFORCING BARS SHALL LAP 40 BAR DIAMETERS. ALL SUCH SPLICES SHALL BE MADE IN A REGION OF COMPRESSION UNLESS OTHERWISE SHOWN.
- ALL REINFORCEMENT BARS SHALL BE SECURELY ANCHORED AND SHALL BE SPACED FROM THE FORMS (UNLESS SHOWN OTHERWISE) AS FOLLOWS: 2" IN BEAMS AND COLUMNS, 1" IN PROTECTED WALLS AND SUSPENDED SLABS, 2" IN UNPROTECTED WALLS, AND 3" ABOVE BOTTOM AND SIDES OF FOOTINGS.
- ALL OPENINGS IN CONCRETE WALLS SHALL BE REINFORCED WITH 2 #5 BARS EXTENDING 2'0" MIN BEYOND THE EDGE OF THE OPENING AT EACH FACE OF OPENING.
- ALL CONCRETE WORK SHALL BE PLACED, CURED, STRIPPED, AND PROTECTED AS DIRECTED BY THE SPECIFICATIONS AND ACI STANDARDS AND PRACTICES.
- BEFORE CONCRETE IS POURED CHECK WITH ALL TRADES TO INSURE PROPER PLACEMENT OF ALL OPENINGS, SLEEVES, CURBS, CONDUITS, BOLTS, INSERTS, ETC. RELATIVE TO WORK.
- CONTRACTOR IS RESPONSIBLE FOR ALL SHORING AND FORMWORK.
- REFER TO ARCHITECTURAL DRAWINGS FOR MOLDS, GROOVES, ORNAMENT, CLIPS OR GROUNDS, REQUIRED TO BE ENCASED IN CONCRETE AND FLOOR LOCATION OF FLOOR FINISHES AND SLAB DEPRESSIONS.
- WELDED WIRE FABRIC SHALL CONFORM TO ASTM A 185 AND SHALL HAVE A MINIMUM SIDE LAP OF 8 IN.
- ALL REINFORCEMENT SHALL BE DETAILED AND PLACED IN ACCORDANCE WITH ACI DETAILING MANUAL 315-95 AND ACI STANDARD 318-95.
- FOR STEPS IN FOUNDATION GREATER THAN 2 FEET, WRAP CORNER W/2- #4 BARS EXTENDING 18" EACH DIRECTION.

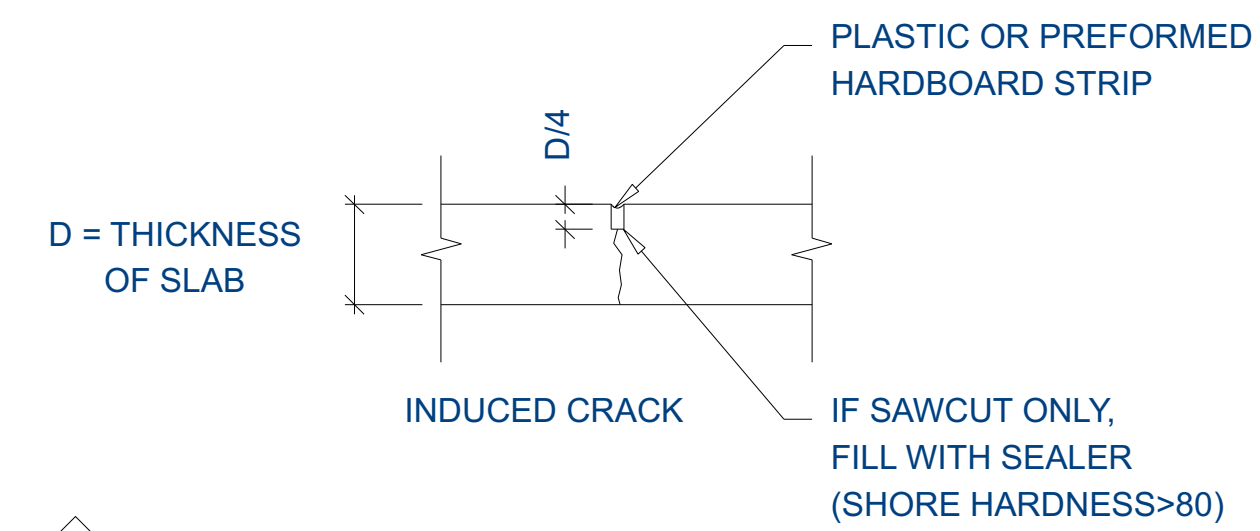

SAWED OR PREMOLDED CONTRACTION JOINT

SCALE: NONE

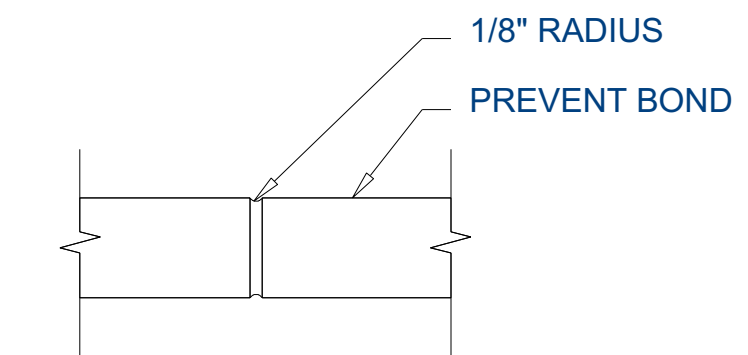

BUTT JOINT CONSTRUCTION JOINT

SCALE: NONE

MINIMUM NAILING SCHEDULE

"CONNECTION"	"NAILING"
1. JOIST TO SILL GIRDER, TOENAIL	3-8d
2. BRIDGING TO JOIST, TOENAIL EA. END	2-8d
3. SOLE PLATE TO JOIST OR BLOCKING	Face Nail 16d @ 16" OC
4. TOP PLATE TO STUD, END NAIL	2-16d
5. STUD TO SOLE PLATE	4-8d TOENAIL, 2-16d END NAIL
6. DOUBLE STUDS, FACE NAIL	16d @ 24" OC
7. DOUBLE TOP PLATES, FACE NAIL	16d @ 16" OC
8. TOP PLATES, LAPS AND INTERSECTIONS, FACE NAIL	2-16d
9. CONTINUOUS HEADERS TWO PIECES, ALONG EA. EDGE ...	16d @ 16" OC
10. CEILING JOISTS TO PLATE, TOENAIL	3-8d
11. CONTINUOUS HEADERS TO STUD, TOENAIL	4-8d
12. CEILING JOISTS, LAPS OVER PARTITIONS, FACE NAIL	3-16-d
13. CEILING JOISTS TO PARALLEL RAFTERS, FACE NAIL	3-16d
14. RAFTER TO PLATE, TOENAIL	3-8d
15. BUILT-UP CORNER STUDS	16d @ 24" OC
16. BUILT-UP GIRDER AND BEAMS	20d @ 32" OC T/B STAGGERED 2-20d @ ENDS & SPLICES

STEEL LINTEL SCHEDULE

CLEAR OPENING	SIZE ANGLE
UP TO 5'-0"	3 1/2" x 3" x 1/4"
5'-1" TO 7'-0"	3 1/2" x 3 1/2" x 1/4"
7'-1" TO 9'-0"	5" x 3" x 1/4"
9'-1" TO 10'-0"	5" x 3" x 5/16"
10'-1" TO 11'-0"	5" x 3" x 3/8"
11'-1" TO 12'-0"	6" x 3" x 3/8"
12'-1" AND OVER	ANALYSIS REQD.

**TABLE OF EQUIVALENT FASTENERS
STAPLES, NAILS AND T-NAILS
(VALID FOR LATERAL LOAD ONLY)**

COMMON NAIL SPACING	EQUIV. SPACING OF APPR. FASTENERS					
	GAUGE	16	15	14	113	131
6d AT	PENETRATION	1"	1"	1"	1 1/4"	1/2"
	4"	3 1/2"	4"	5"	4"	5"
	6"	5"	6"	7"	6"	7 1/2"
	8"	6 1/2"	8"	9 1/2"	8"	10"
	10"	8 1/2"	10"	12"	10"	12"
8d AT	12"	10"	12"	14 1/2"	12"	14 1/2"
	3"	2"	2 1/2"	3"	2 1/2"	3"
	4"	2 1/2"	3 1/2"	4"	3 1/2"	4"
	6"	4"	5"	6"	5"	6"
	8"	5 1/2"	6 1/2"	8"	6 1/2"	8"
10d AT	10"	6 1/2"	8"	10"	8"	10"
	12"	8"	10"	12"	9 1/2"	12"
	4"	2"	2 1/2"	3"	2 1/2"	3 1/2"
	6"	3 1/2"	4"	5"	4"	5"
	8"	4 1/2"	5 1/2"	6 1/2"	5 1/2"	7"
10"	5 1/2"	7"	8"	6 1/2"	8 1/2"	
12"	6 1/2"	8"	9 1/2"	8 1/2"	10"	

NOTE: PENETRATION IS THE DEPTH OF EMBEDMENT OF THE STAPLE OR NAIL INTO THE MAIN MEMBER REQUIRED TO ATTAIN ITS FULL CAPACITY (SHEAR VALUE) FOR LATERAL LOADING.

LINTEL

LINTELS CARRY MASONRY ONLY, WHERE FLOORS, ROOFS, OR CONCENTRATED LOADS OCCUR, FURTHER ANALYSIS IS NECESSARY. PROVIDE 1" OF BEARING EACH END FOR EACH FOOT OF SPAN. MINIMUM BEARING 6" EACH SIDE ON OPENING USE THIS SCHEDULE UNLESS NOTED OTHERWISE.
Min. 5 x 3 1/2 x 5/16 Steel Angle

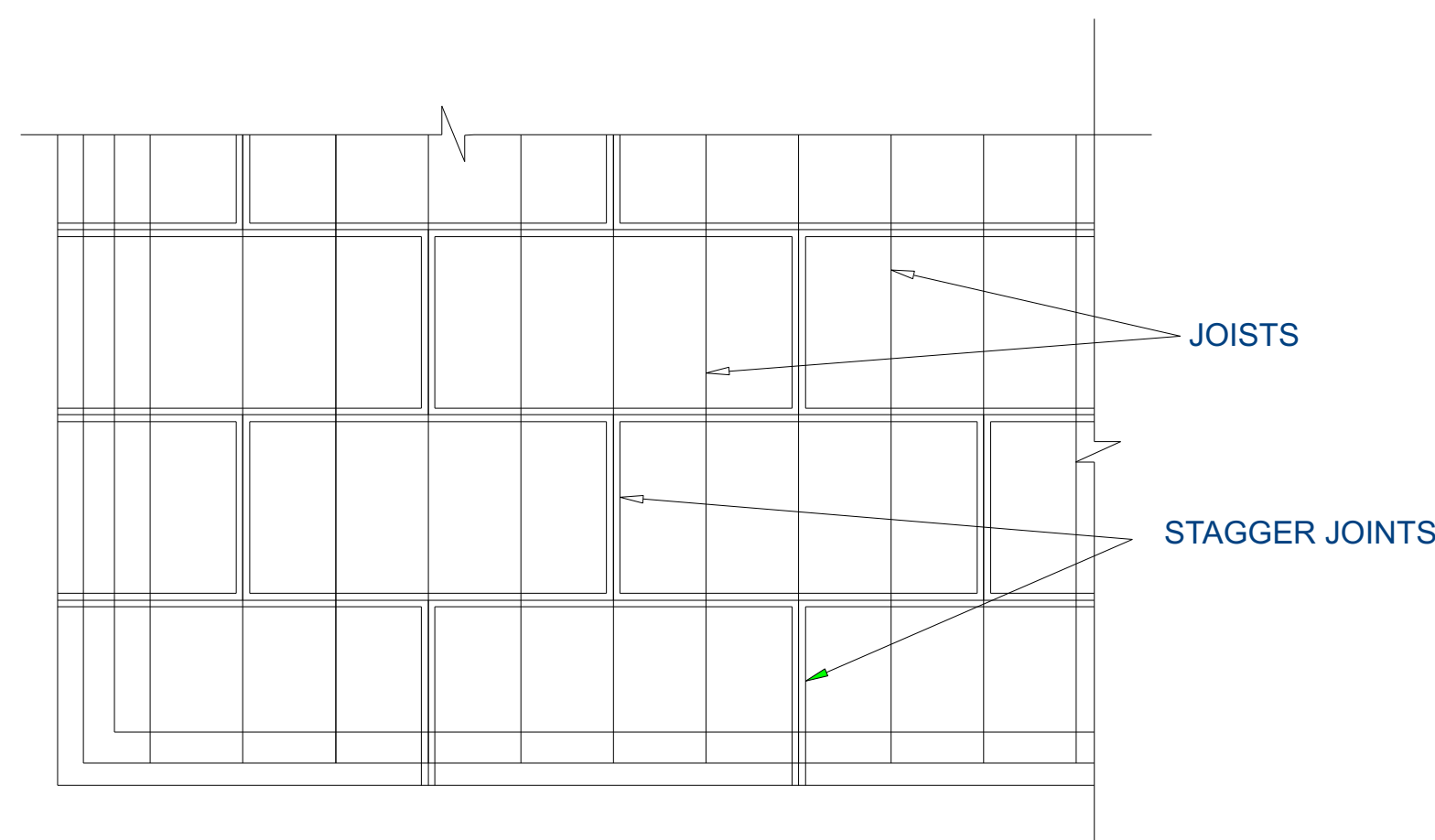
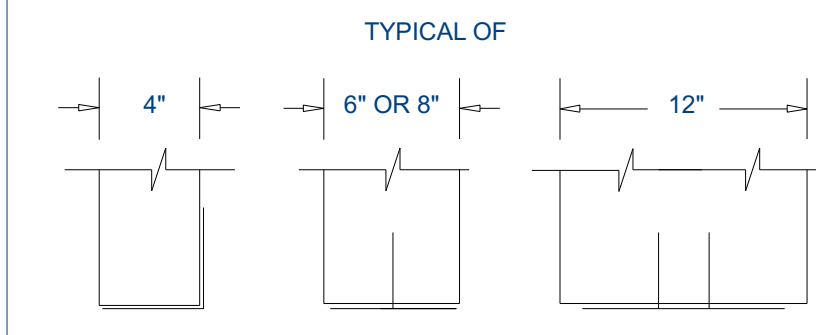

HORIZONTAL SHEATHING LAYOUT

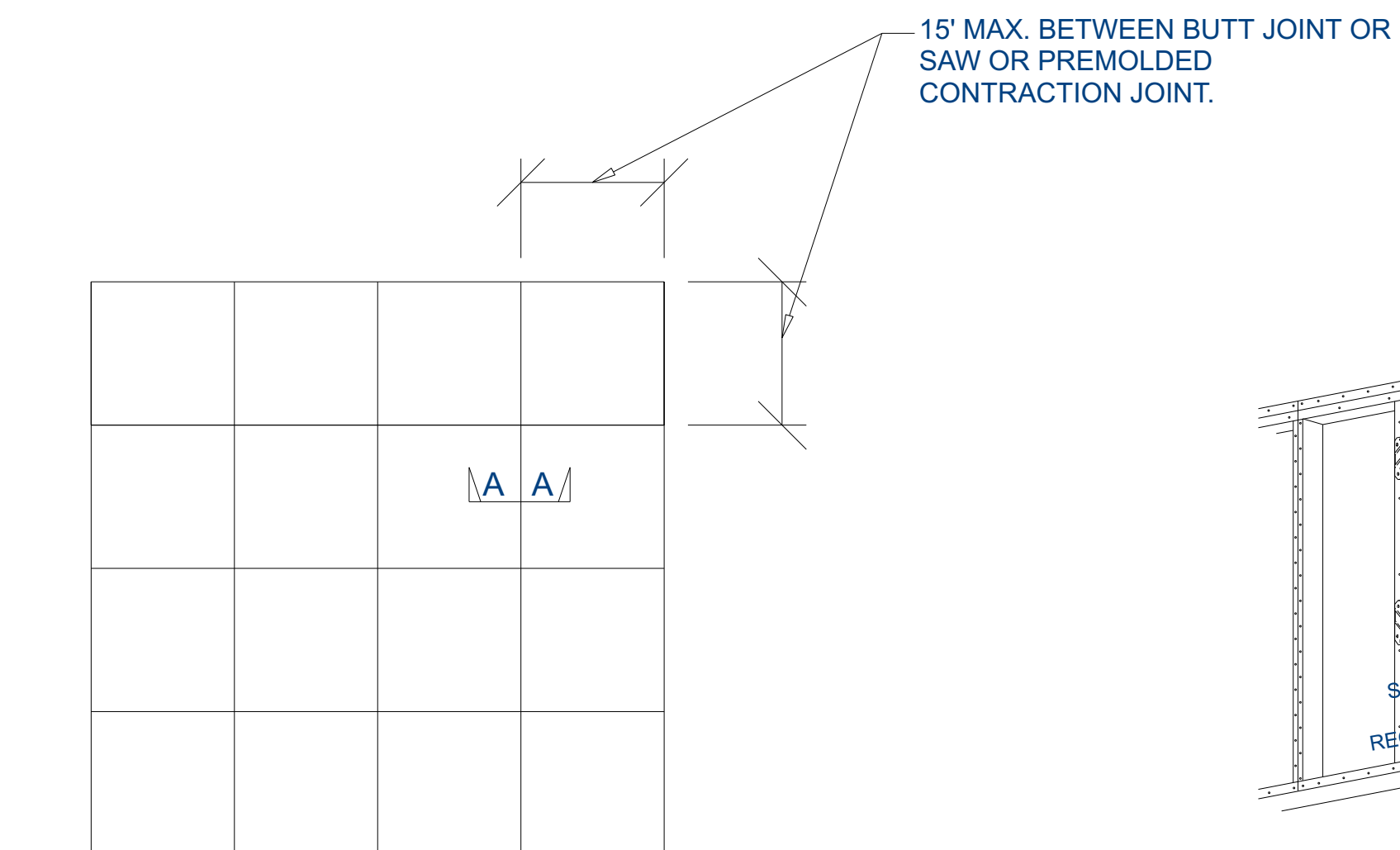

SLAB ON GRADE CONTROL JOINTS

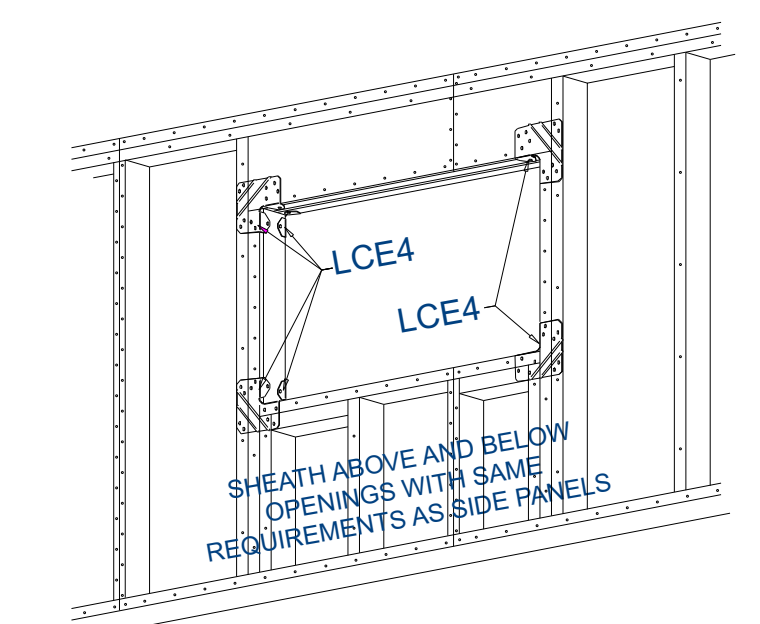

LCE4 DETAIL

NOT TO SCALE

Stamp:

Not Approved For Construction Without Engineer Stamp

SILVERPEAK ENGINEERING
177 E. ANTELOPE DR. #B
LAYTON, UTAH 84041
PHONE: (801) 392-4211
FAX: (801) 392-2941

Architectural Design: **Harker Design**
5224 South Yellowstone Ave., Idaho Falls, Id
208-523-3522 --- www.harkerdesign.com

Project: **FRAZIER RESIDENCE**
Address: Lot 6 Block 2, Water Front Estates, Rigby, Idaho

Structural Notes

Issue Date:
8/17/2017
S1
No Scale

CONCRETE WALL SCHEDULE

WALL HEIGHT	TOP EDGE SUPPORT	MINIMUM THICKNESS	REINFORCING		STEEL AT OPENINGS	REMARKS
			VERTICAL	HORIZONTAL		
2'-0"	None	8"	#4 DOWELS @ 24" O.C.	2- #4 BARS	ABOVE: 2- #4 BARS	
4'-0"		8"	#4 DOWELS @ 24" O.C.	4- #4 BARS		
6'-0"	FLOOR OF ROOF DIAPHRAGM	8"	#4 DOWELS @ 24" O.C.	5- #4 BARS	EACH SIDE: 1- #4 BAR	
8'-0"		8"	#4 DOWELS @ 24" O.C.	6- #4 BARS		
9'-0"		8"	#4 DOWELS @ 16" O.C.	7- #4 BARS		BELOW: 1- #4 BAR

- NOTES:**
- FOR WALLS WITH ONE MAT OF STEEL, VERTICAL STEEL TO BE PLACED IN CENTER OF WALL AND EXTEND TO WITHIN THREE INCHES OF THE TOP OF THE WALL. DOWELS OF #4 BARS TO MATCH VERTICAL STEEL PLACEMENT SHALL BE PROVIDED IN THE FOOTING EXTENDING 24 INCHES INTO THE FOUNDATION WALL.
 - ONE HORIZONTAL BAR SHALL BE LOCATED IN THE TOP 4", ONE BAR IN THE BOTTOM 4" AND THE OTHER BARS EQUALLY SPACED. CORNER REINFORCING SHALL BE PROVIDED SO AS TO LAP 24".
 - BARS SHALL BE PLACED WITHIN 2" OF OPENINGS AND EXTEND 24" BEYOND THE EDGE OF THE OPENING. VERTICAL BARS MAY TERMINATE 3" FROM THE TOP OF THE CONCRETE.
 - PLACE 1/2" x 10" ANCHOR BOLTS AT 32" O.C. IN TOP OF ALL WALLS TO RECEIVE SILL PLATES. CAST ANCHOR BOLTS A MINIMUM OF 7" INTO CONCRETE. USE 3"x3"x1/4" WASHERS ON ALL ANCHOR BOLTS. EACH WALL SEGMENT MUST HAVE 2 ANCHOR BOLTS MINIMUM.
 - INTEL DEPTH SHALL BE 2" FOR EACH FOOT OF OPENING WIDTH, MIN. 6".

FOOTING SCHEDULE

Mark	Width	Length	Thick	Crosswise Reinforcing			Lengthwise Reinforcing			Remarks		
				No.	Size	Lengt Spac.	No.	Size	Lengt Spac.			
(F-1)	2'-0"	Cont.	10"	--	None	Req'd	--	2	#4	Cont.	Even	
(F-2)	3'-3"	7'-8"	12"	8-	#4	2'-9"	Even	4	#4	7'-2"	Even	Fireplace Footing
(F-3)	3'-0"	3'-0"	10"	3	#4	2'-6"	EVEN	3	#4	2'-6"	Even	

- NOTES:**
- PLACE ALL FOOTING REINFORCING 3" FROM BOTTOM OF FOOTING WITH 3" CLEAR ON SIDES UNLESS NOTED OTHERWISE

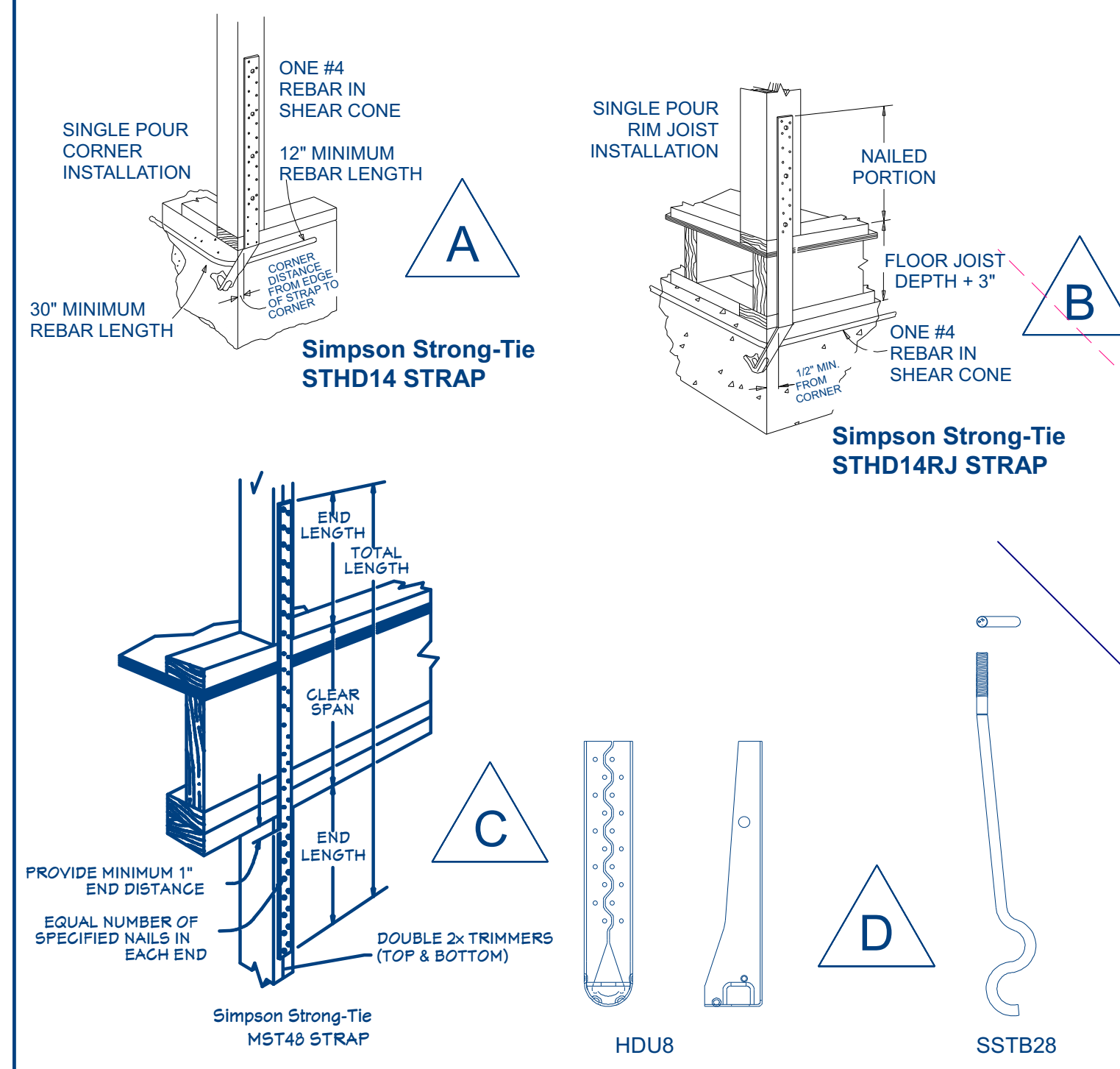

HOLDDOWN & STRAP SCHEDULE

Mark	Description
A	Simpson STHD14 Holddown
B	Simpson STHD14RJ Holddown
C	Simpson MST48 Strap
D	Simpson HDU8 w/SSTB28

- ANCHOR ALL HOLDDOWNS THROUGH A MINIMUM OF (2) 2 x STUDS.
- THE FOUNDATION CONTRACTOR SHALL PLACE ALL HOLDDOWN STRAPS TO LINE UP WITH A CORNER, WINDOW OR DOOR JAMB STUD IN THE FRAMED WALL DIRECTLY ABOVE.

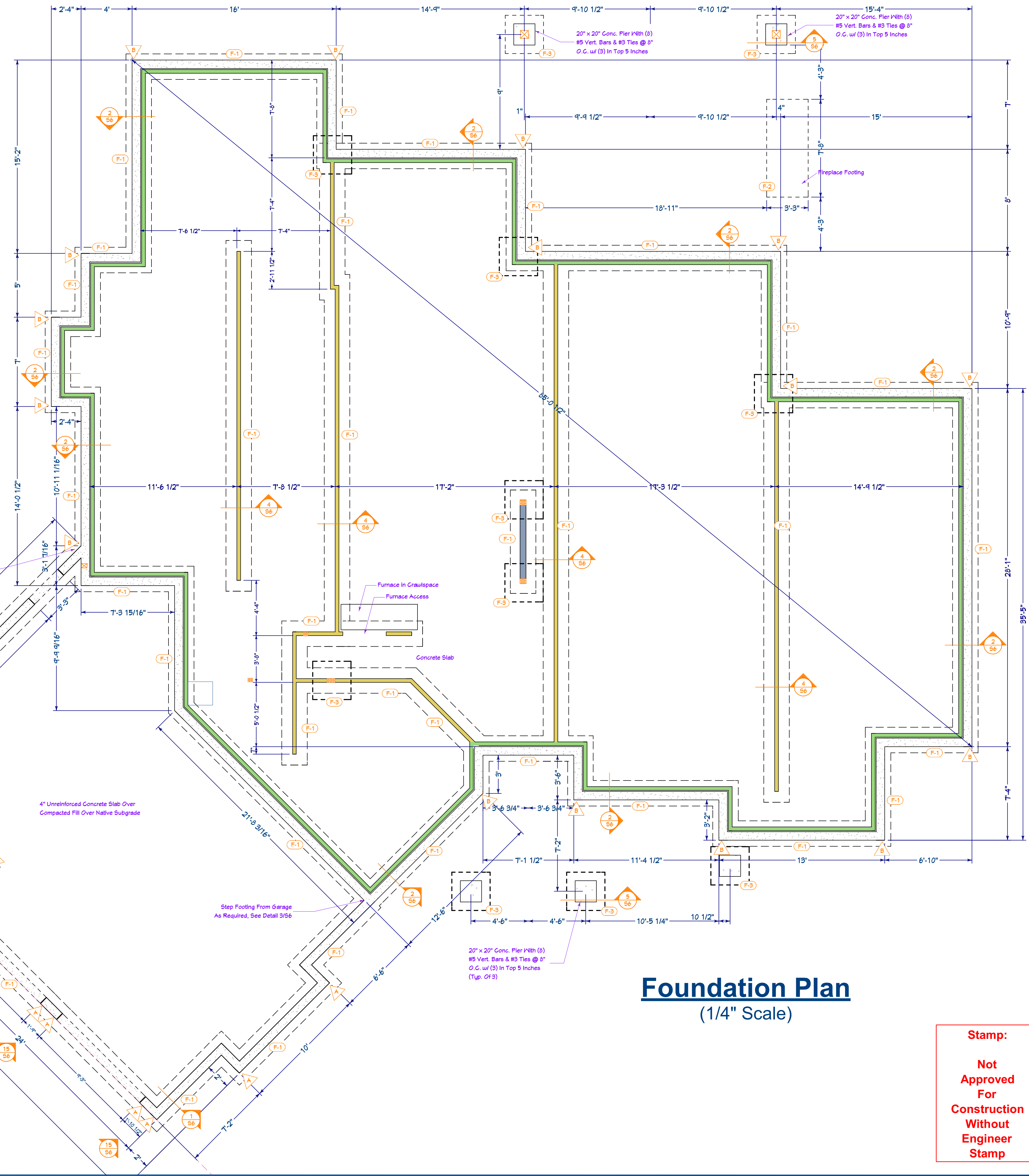

Foundation Plan
(1/4" Scale)

Stamp:

Not
Approved
For
Construction
Without
Engineer
Stamp

177 E ANTELOPE DR. #B
LAYTON, UT 84041
PHONE: (801) 392-4211
FAX: (801) 392-2941

SILVERPEAK
ENGINEERING

Architectural Design:
Harker Design
5224 South Yellowstone Ave., Idaho Falls, Id
208-523-3322 www.harkerdesign.com

Project:
FRAZIER RESIDENCE
Address: Lot 6 Block 2, Water Front Estates, Rigby, Idaho

Foundation Plan

Issue Date:
8/17/2017
S2
No Scale

GENERAL ROOF FRAMING NOTES

1. USE DOUGLAS FIR-LARCH #2 AND BETTER FOR ALL SAWN LUMBER BEAMS & STRUCTURAL COLUMNS
2. USE 1.9E (MIN) LVL BEAMS
3. CONNECT 4 PLY AND GREATER LVL BEAMS WITH (2) ROWS 1/2" THRU BOLTS @ 12" O.C. (SEE MANUFACTURERS SPECIFICATIONS)
4. CARRY ALL COLUMN LOADS DOWN TO FOOTING OR FOUNDATION
5. PROVIDE SOLID BLOCKING OR SQUASH BLOCKS IN JOIST SPACE AT ALL COLUMN LOCATIONS
6. CONNECT ALL TRUSSES PER TRUSS MANUFACTURER SPECIFICATIONS
7. SHEATH ROOF PRIOR TO CONSTRUCTING OVERBUILDS- ROOF SHEATHING SHALL EXTEND BENEATH OVERBUILDS.
8. PROVIDE (MIN) (4) 2x4 BUILT UP COLUMN TO SUPPORT ALL GIRDER TRUSS LOADS UNLESS NOTED OTHERWISE
9. USE MIN. 2x6 OVERBUILD RAFTERS @ 24" O.C. - DO NOT SPAN RAFTERS MORE THAN 6'-0" AT OVERBUILDS
10. ALL EXTERIOR HEADERS SHALL BE (2) 2X10 U.N.O.
11. See Detail 12/S6 For Typical Beam Connection Details

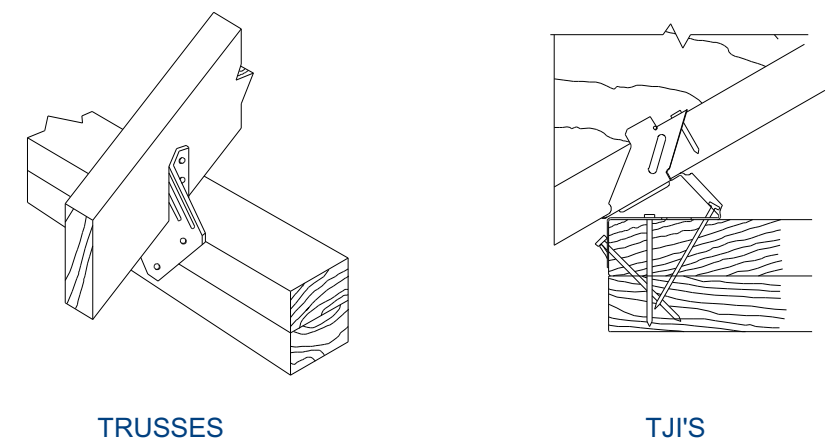

ROOF JOIST CONNECTIONS

NOT TO SCALE

SHEARWALL NOTES

1. ALL EXTERIOR WALLS SHALL BE SHEATHED AND NAILED WITH 7/16" APA RATED OSB SHEATHING OR PER SHEARWALL SCHEDULE.
2. SHEATHING SHALL EXTEND CONTINUOUS FROM SILL PLATE TO TOP PLATE OF UPPER WALL AND BE NAILED PER SHEARWALL SCHEDULE.
3. NAILS SHALL BE PLACED NOT LESS THAN 1/2" FROM EDGE OF PANEL AND DRIVEN SO THAT THEIR HEAD OR CROWN IS FLUSH WITH THE SURFACE OF THE SHEATHING.
4. ALL EXTERIOR WALLS ARE TO BE NAILED AS SW-1 UNLESS NOTED OTHERWISE.
5. AT LEAST (2) OF THE GARAGE RETURNS MUST BE SHEARWALLS. MINIMUM GARAGE RETURN SHEARWALL IS 2'-0".
6. ALL ANCHORS ARE SIMPSON STRONG-TIE OR EQUIVALENT.
7. INSTALL HOLDDOWNS AND STRAPS PER MANUFACTURER'S SPECIFICATIONS.
8. ALL HOLDDOWNS AND STRAPS MUST BE CONNECTED TO AT LEAST (2) FULL-LENGTH STUDS.

STUD HEIGHT CHART FOR ALL STUDS U.N.O.

STUDS	SPACING	MAX. HEIGHT
2x4	16" O.C.	10'-0"
2x4	12" O.C.	11'-6"
2x6	16" O.C.	16'-0"
2x6	12" O.C.	18'-0"
5 1/2" LVL 2x6 T.S.	16" O.C.	20'-0"

T.S. = TIMBERSTRAND

ROOF SHEATHING NOTES:

1. ROOF SHEATHING SHALL BE 5/8" APA RATED SHEATHING W/SPAN RATING OF 32/16 NAILED WITH 8d NAILS AT 6" O.C. AT ALL PANEL ENDS, SUPPORTED EDGES, TOP OF SHEAR WALLS AND ALL BLOCKING; 8d NAILS AT 12" O.C. ALONG INTERMEDIATE FRAMING MEMBERS. PROVIDE 1/8" GAP BETWEEN ALL PANELS.
2. BLOCK JOISTS SOLID AT ALL BEARING POINTS.

ROOF TRUSS NOTES:

1. TRUSSES SHALL BE DESIGNED FOR 35 PSF LIVE LOAD.
2. DESIGN TRUSSES TO LIMIT DEFLECTION TO SPAN (IN.) DIVIDED BY 240.
3. CHECK DIMENSIONS WITH ARCH. DRAWINGS. TRUSS MANUFACTURER IS RESPONSIBLE TO PROVIDE WEB AND CHORD MEMBERS TO SATISFY LOAD REQUIREMENTS.
4. TRUSS MANUFACTURER SHALL SUBMIT CALCULATIONS AND SHOP DRAWINGS FOR APPROVAL BY ENGINEER.

DESIGN CRITERIA:

GOVERNING CODE2012 IBC
 SEISMIC MAPPED ACCELERATION.....180
 I = 1.00
 R = 6
 Sds = 1.17g

BASIC WIND SPEED 115 MPH EXPOSURE C
 I = 1.00

ROOF
 DEAD LOAD 15 PSF
 LIVE LOAD 35 P

FLOOR
 DEAD LOAD 15 PSF
 LIVE LOAD 40 PSF

SOIL BEARING PRESSURE 1500 PSF (ASSUMED)

*** STANDARD OCCUPANCY ***

SHEARWALL SCHEDULE

MARK	SHEATHING	NAILING REQUIREMENTS		ANCHOR BOLTS		SILL PLATE	NOTES
		EDGE	FIELD	DIAMETER	SPACING		
SW-1	7/16" OSB ONE SIDE	8d @ 6" o.c.	8d @ 12" o.c.	1/2"	32" O.C.	2x	1,2,3,4,5
SW-2	7/16" OSB ONE SIDE	8d @ 4" o.c.	8d @ 12" o.c.	1/2"	32" O.C.	2x	1,2,3,4,5
SW-3	7/16" OSB ONE SIDE	8d @ 3" o.c.	8d @ 12" o.c.	1/2"	32" O.C.	2x	1,2,3,4,5,6
SW-4	7/16" OSB BOTH SIDES	8d @ 4" o.c.	8d @ 12" o.c.	5/8"	16" O.C.	2x	1,2,3,4,5,6,7

NOTES:

1. APPLY 7/16" APA OSB OVER DOUGLAS FIR OR SOUTHERN PINE FRAMING SPACED @ 16" O.C.
2. NAIL OR STAPLE SHEATHING ALONG INTERMEDIATE STUDS @ 12" O.C.
3. BLOCK ALL PANEL EDGES
4. PROVIDE 3" x 3" x 1/4" PLATE WASHERS ON ANCHOR BOLTS (Typical)
5. ALL SHEATHING SHALL EXTEND CONTINUOUS FROM SILL PLATE TO ROOF OR FLOOR SHEATHING.
6. FRAMING AT ADJOINING PANELS SHALL BE 3" NOMINAL OR (2) 2x NAILED TOGETHER WITH (2) ROWS OF 16d COMMON NAILS @ 12" O.C.
7. OFFSET PANEL JOINTS TO AVOID SPLITTING THE STUDS.
8. INSTALL SIMPSON LCE4 CONNECTORS ON EACH CORNER OF WINDOWS NOTED AS "LCE4" See Detail 17/S7

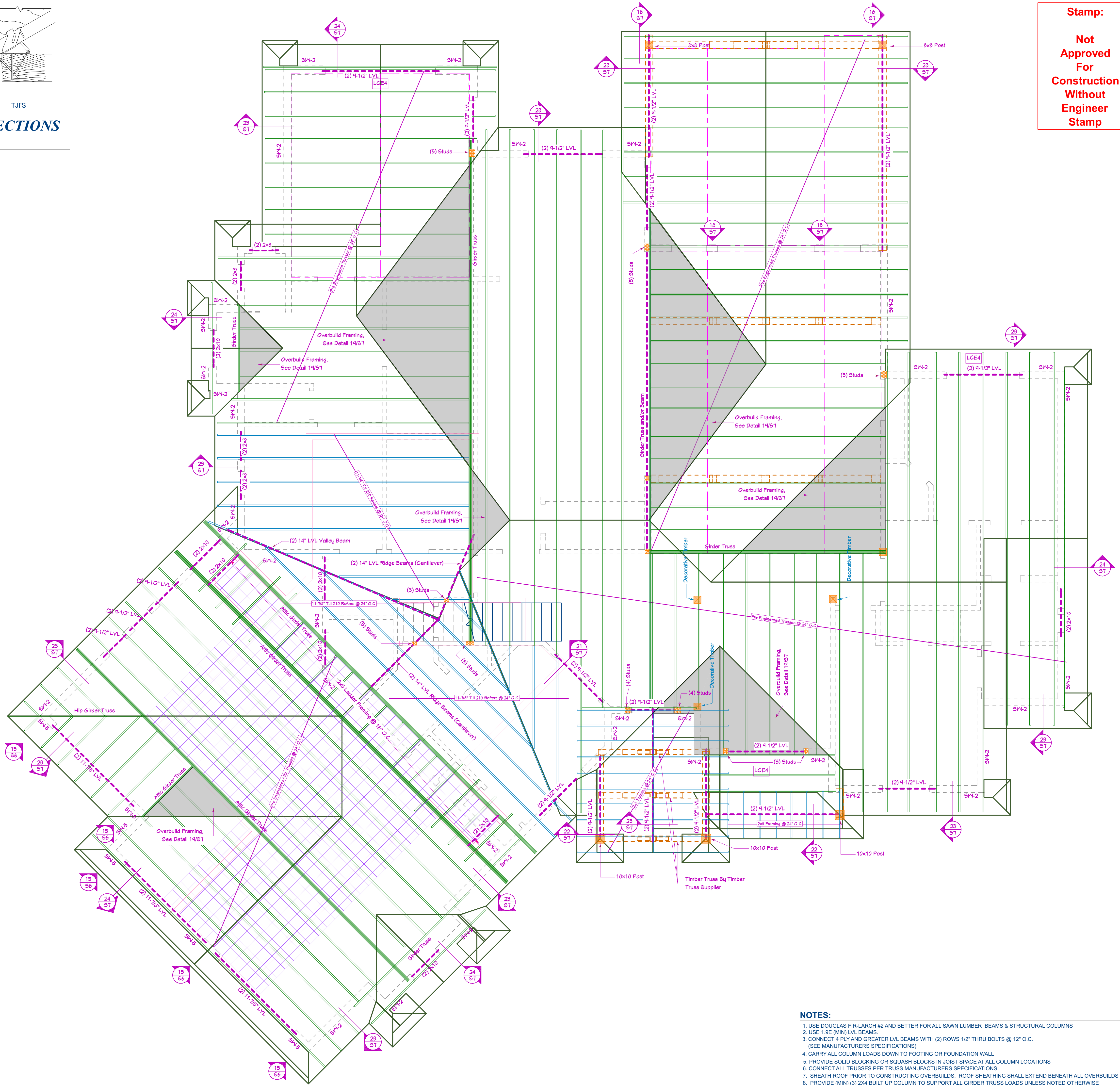

NOTES:

1. USE DOUGLAS FIR-LARCH #2 AND BETTER FOR ALL SAWN LUMBER BEAMS & STRUCTURAL COLUMNS
2. USE 1.9E (MIN) LVL BEAMS
3. CONNECT 4 PLY AND GREATER LVL BEAMS WITH (2) ROWS 1/2" THRU BOLTS @ 12" O.C. (SEE MANUFACTURERS SPECIFICATIONS)
4. CARRY ALL COLUMN LOADS DOWN TO FOOTING OR FOUNDATION WALL
5. PROVIDE SOLID BLOCKING OR SQUASH BLOCKS IN JOIST SPACE AT ALL COLUMN LOCATIONS
6. CONNECT ALL TRUSSES PER TRUSS MANUFACTURERS SPECIFICATIONS
7. SHEATH ROOF PRIOR TO CONSTRUCTING OVERBUILDS. ROOF SHEATHING SHALL EXTEND BENEATH ALL OVERBUILDS
8. PROVIDE (MIN) (3) 2X4 BUILT UP COLUMN TO SUPPORT ALL GIRDER TRUSS LOADS UNLESS NOTED OTHERWISE
9. USE MIN. 2x6 OVERBUILD RAFTERS @ 24" O.C. - DO NOT SPAN RAFTERS MORE THAN 6'-0" AT OVERBUILDS.

Stamp:
 Not
 Approved
 For
 Construction
 Without
 Engineer
 Stamp

SILVERPEAK ENGINEERING
 177 E ANTELOPE DR. #B
 LAYTON, UT 84041
 PHONE: (801) 392-4211
 FAX: (801) 392-2941

Architectural Design:
Harker Design
 5224 South Yellowstone Ave., Idaho Falls, Id
 208-523-3322 www.harkerdesign.com

Project:
FRAZIER RESIDENCE
 Address: Lot 6 Block 2, Water Front Estates, Rigby, Idaho

Roof Framing Plan

Issue Date:
 8/17/2017
SS
 No Scale

Stamp:
Not Approved For Construction Without Engineer Stamp

SILVERPEAK ENGINEERING
177 E ANTELOPE DR. #B
LAYTON, UT 84041
PHONE: (801) 392-4211
FAX: (801) 392-2941

Architectural Design: Harker Design
5224 South Yellowstone Ave., Idaho Falls, Id
208-523-3322 www.harkerdesign.com

Project: FRAZIER RESIDENCE
Address: Lot 6 Block 2, Water Front Estates, Rigby, Idaho

Structural Details

Issue Date: 8/17/2017
S6
No Scale

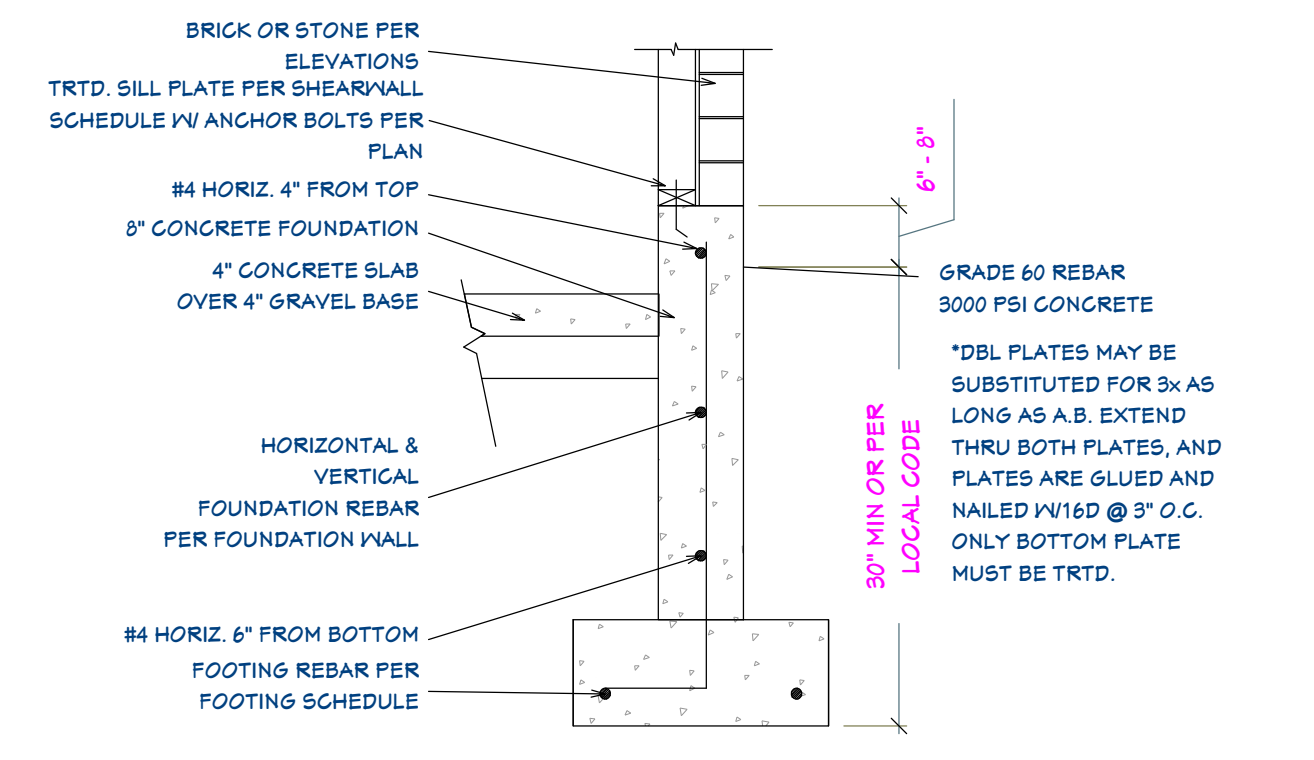

GARAGE FOUNDATION DETAIL
NOT TO SCALE
1
S6

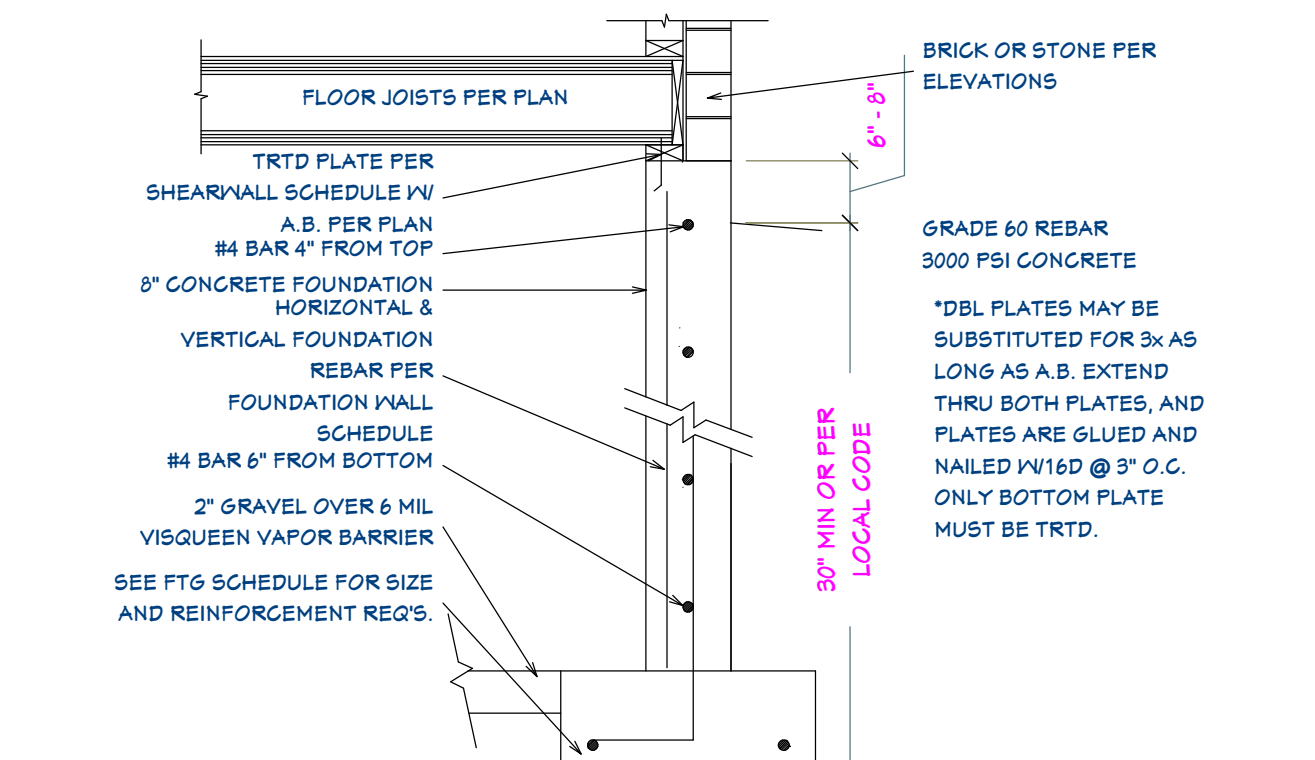

HOUSE FOUNDATION DETAIL
NOT TO SCALE
2
S6

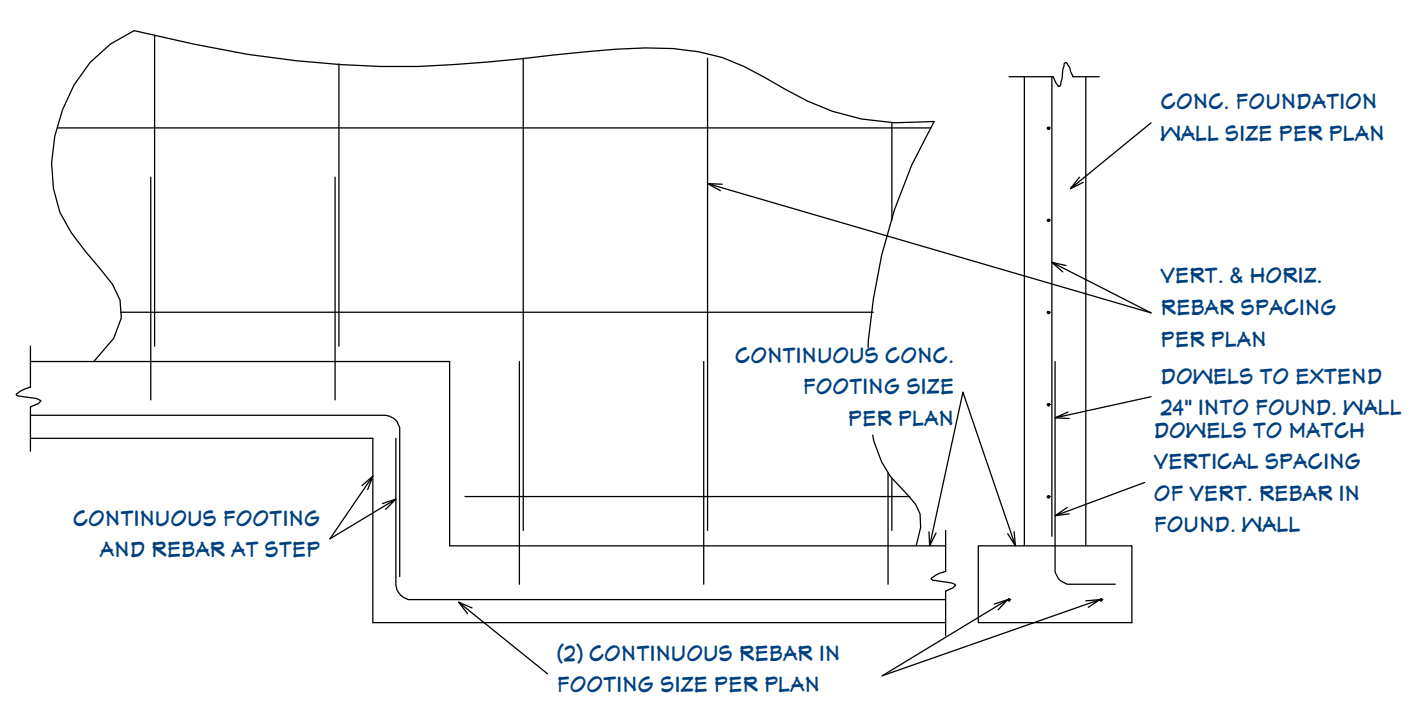

FOOTING STEP DETAIL
NOT TO SCALE
3
S6

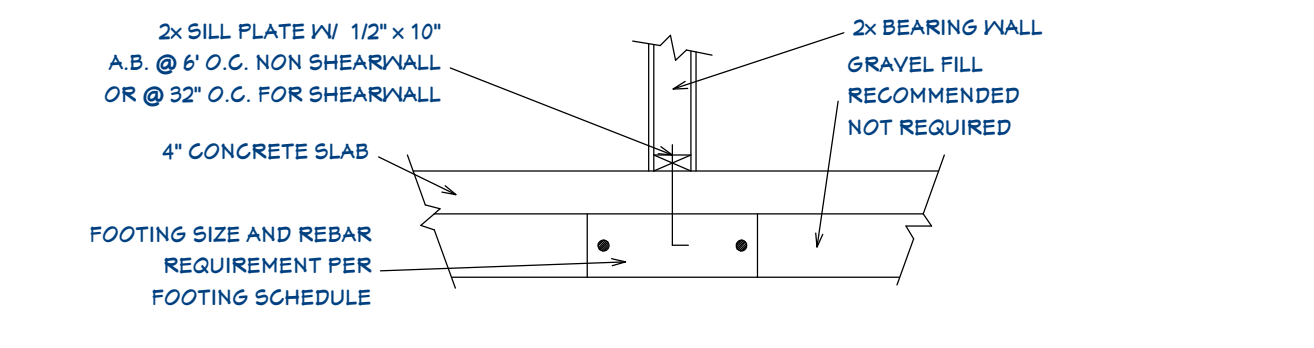

INTERIOR FOOTING DETAIL
NOT TO SCALE
4
S6

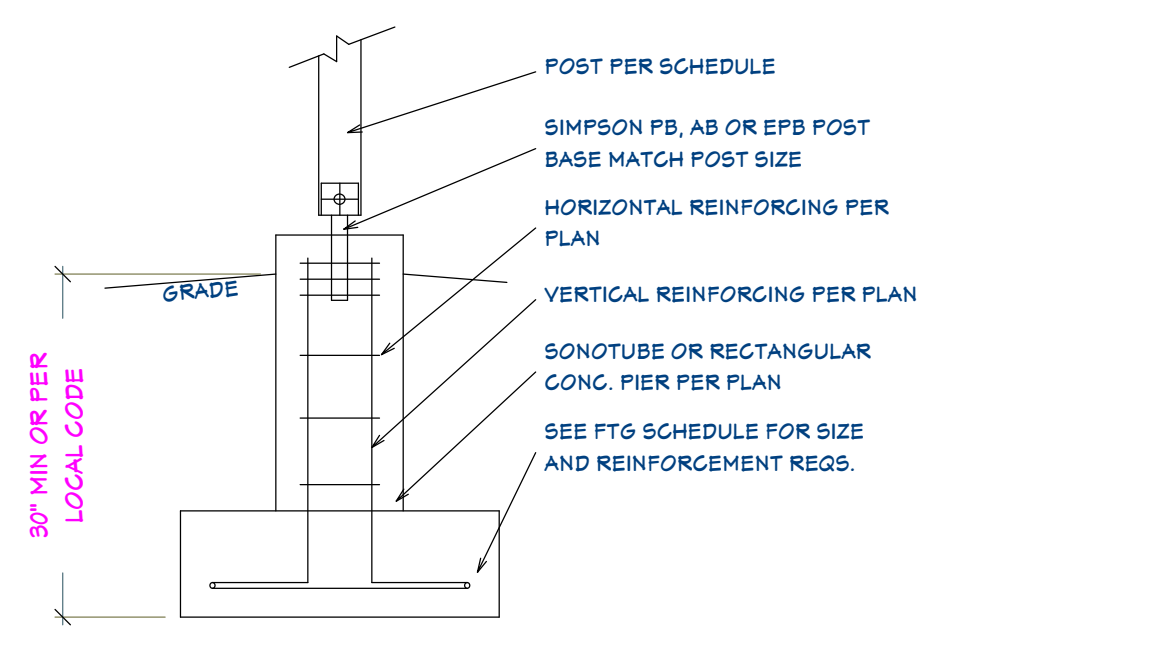

PIER DETAIL
NOT TO SCALE
5
S6

NOT USED
NOT TO SCALE
6
S6

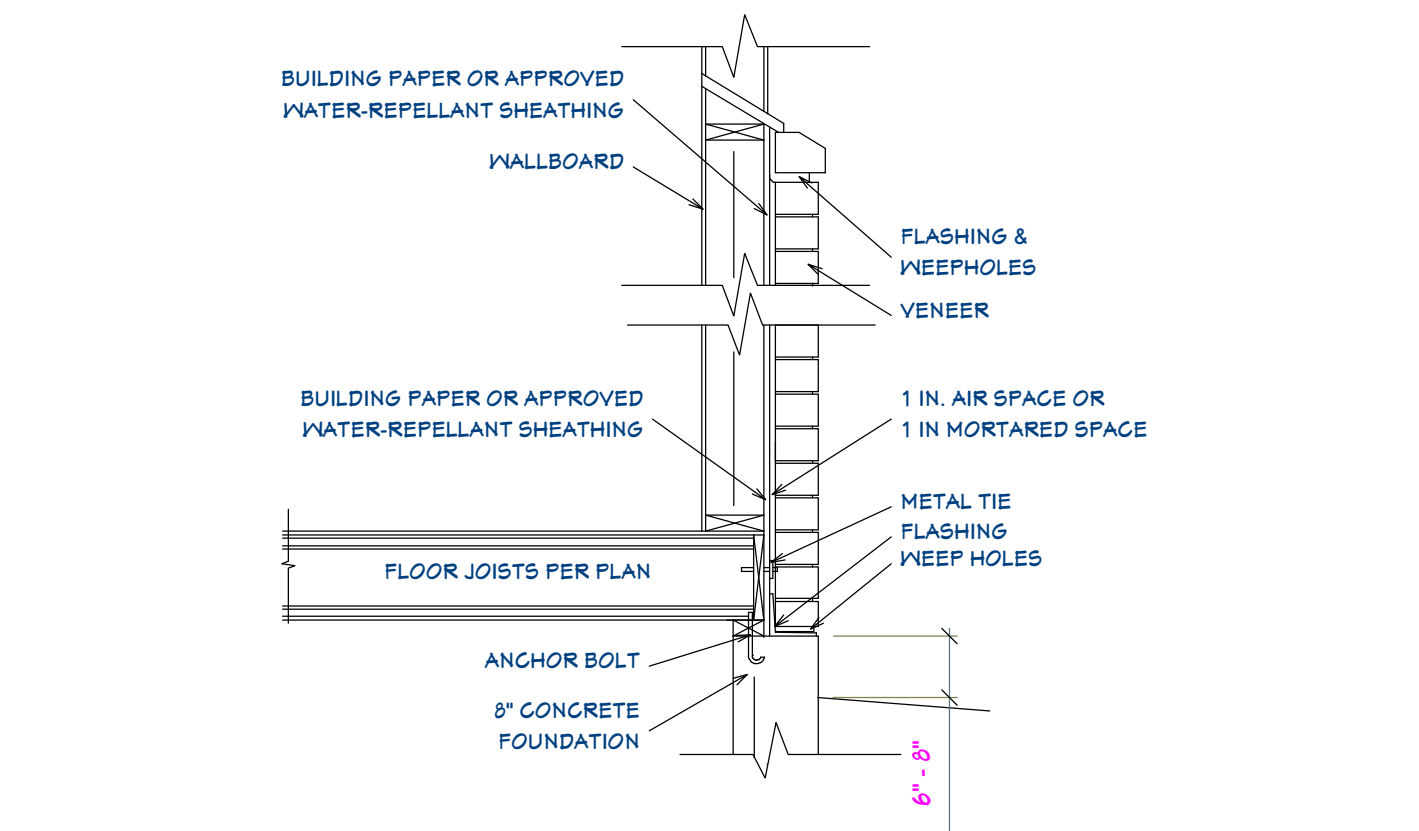

MASONRY VENEER WALL DETAIL
NOT TO SCALE
7
S6

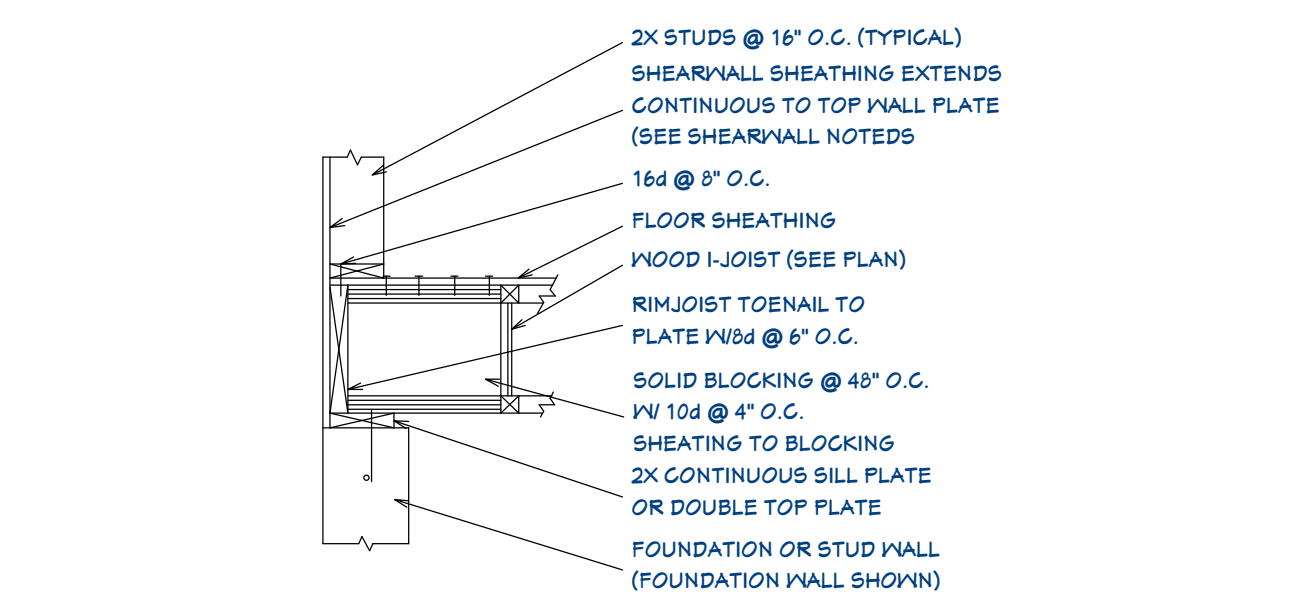

WOOD I-JOIST DETAIL
NOT TO SCALE
8
S6

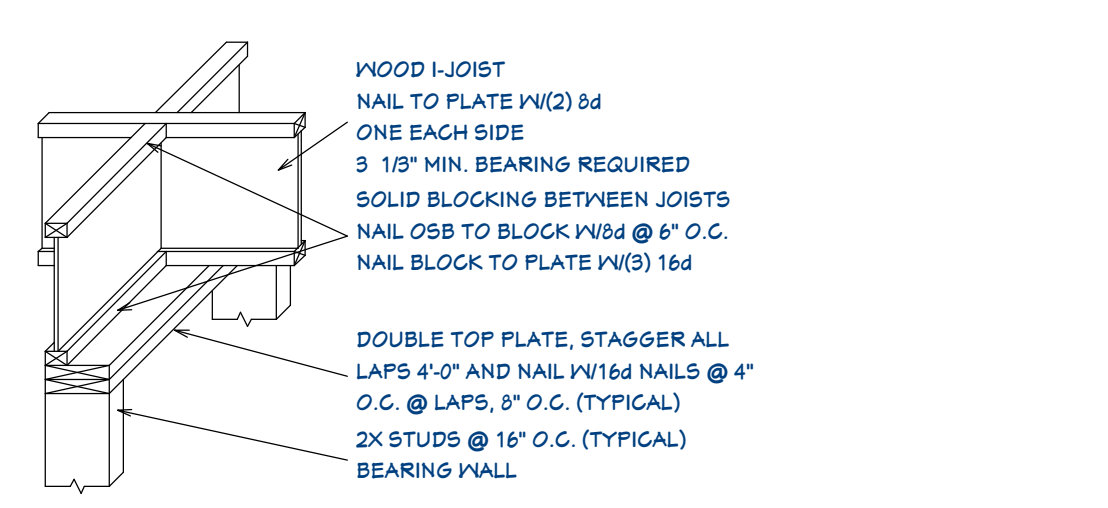

WOOD I-JOIST DETAIL
NOT TO SCALE
9
S6

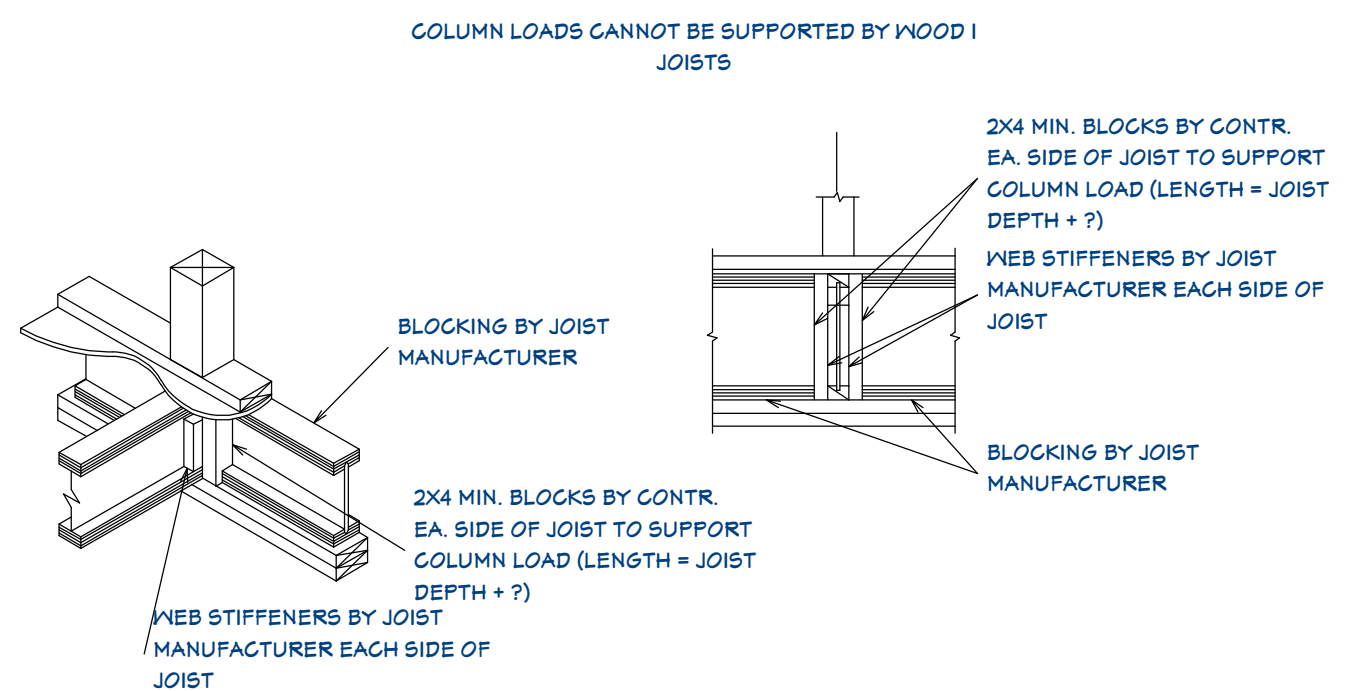

SOLID BLOCKING DETAIL
NOT TO SCALE
10
S6

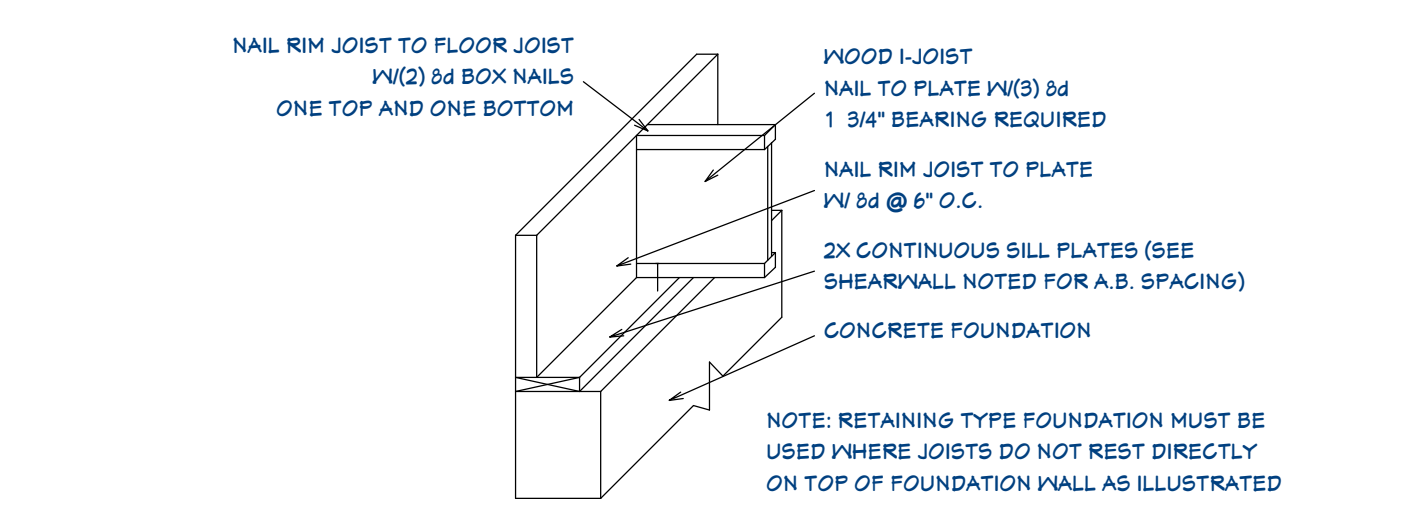

WOOD I-JOIST DETAIL
NOT TO SCALE
11
S6

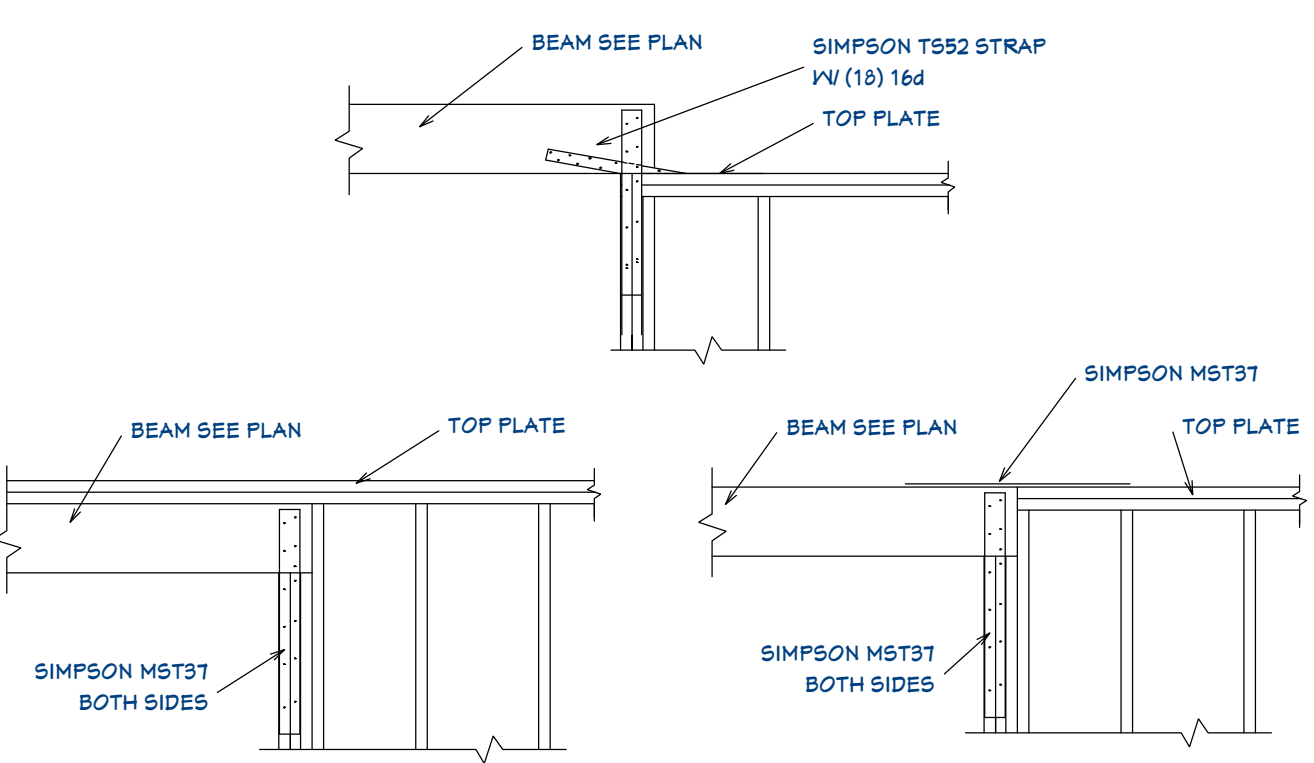

BEAM CONNECTIONS
NOT TO SCALE
12
S6

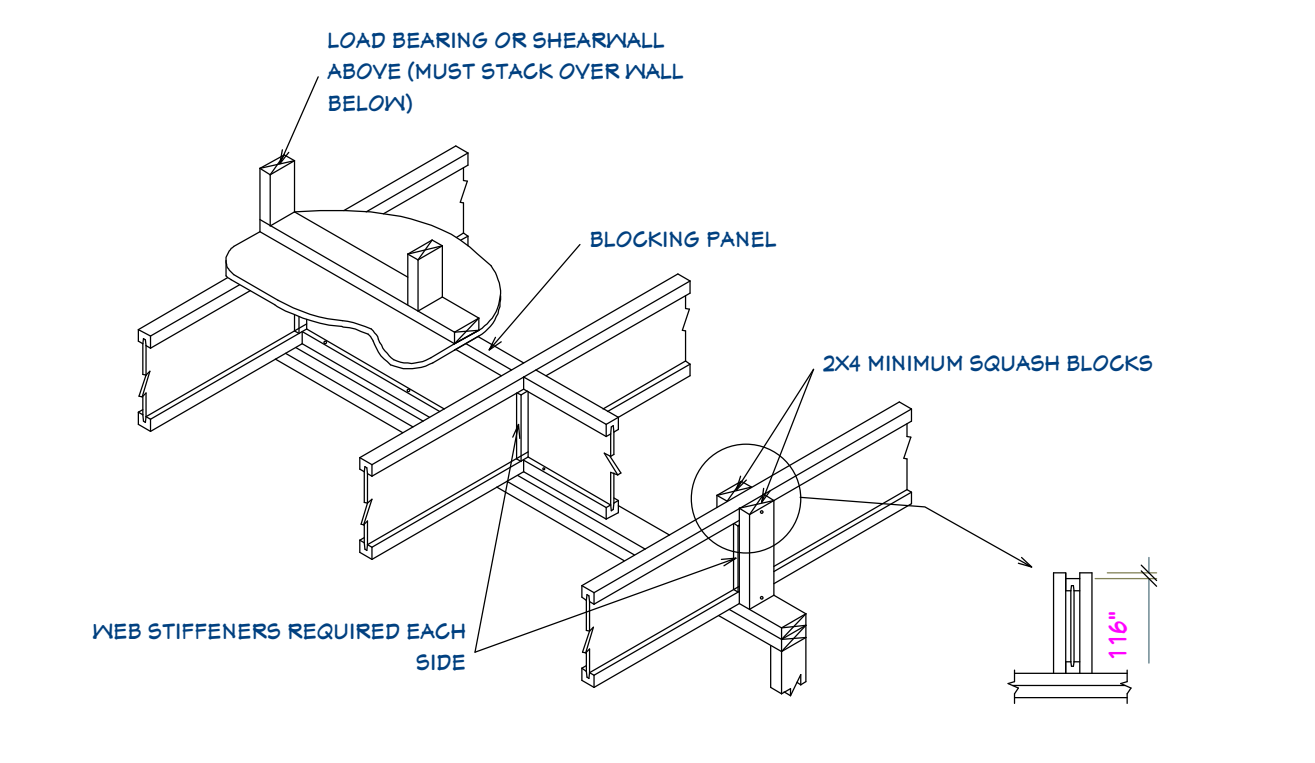

BLOCKING DETAIL
NOT TO SCALE
13
S6

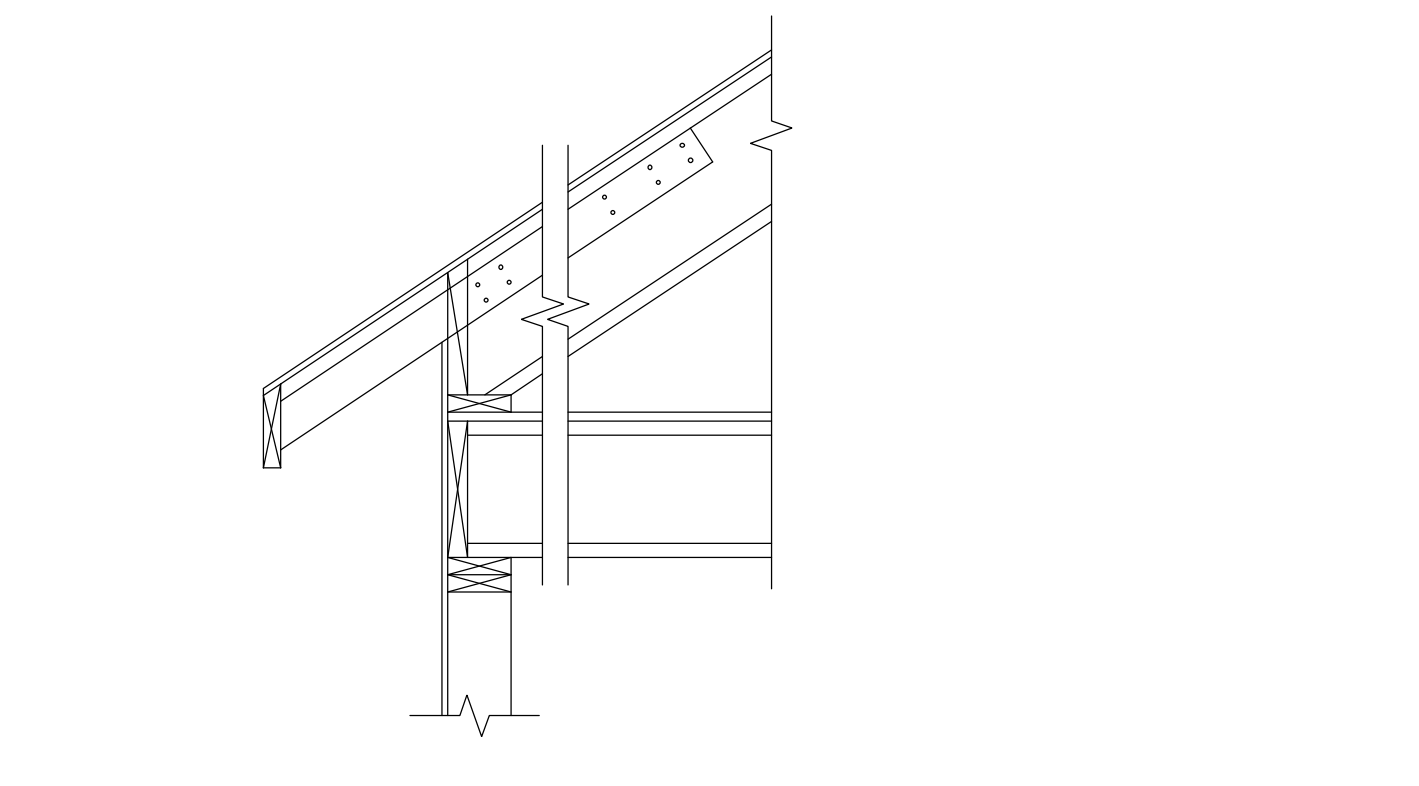

GARAGE ROOF JOIST AT FLOOR INTERFACE
NOT TO SCALE
14
S6

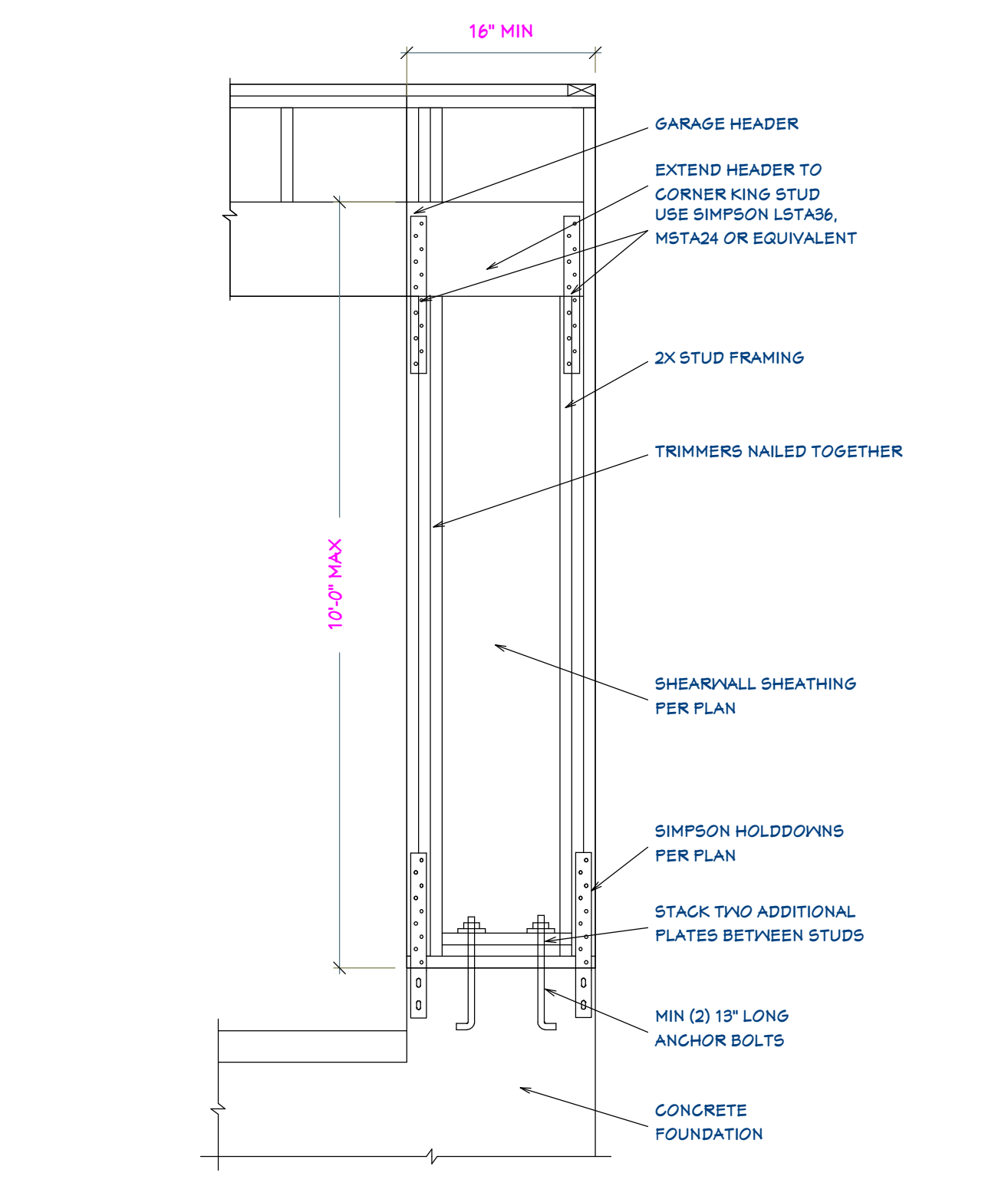

GARAGE RETURN DETAIL
NOT TO SCALE
15
S6

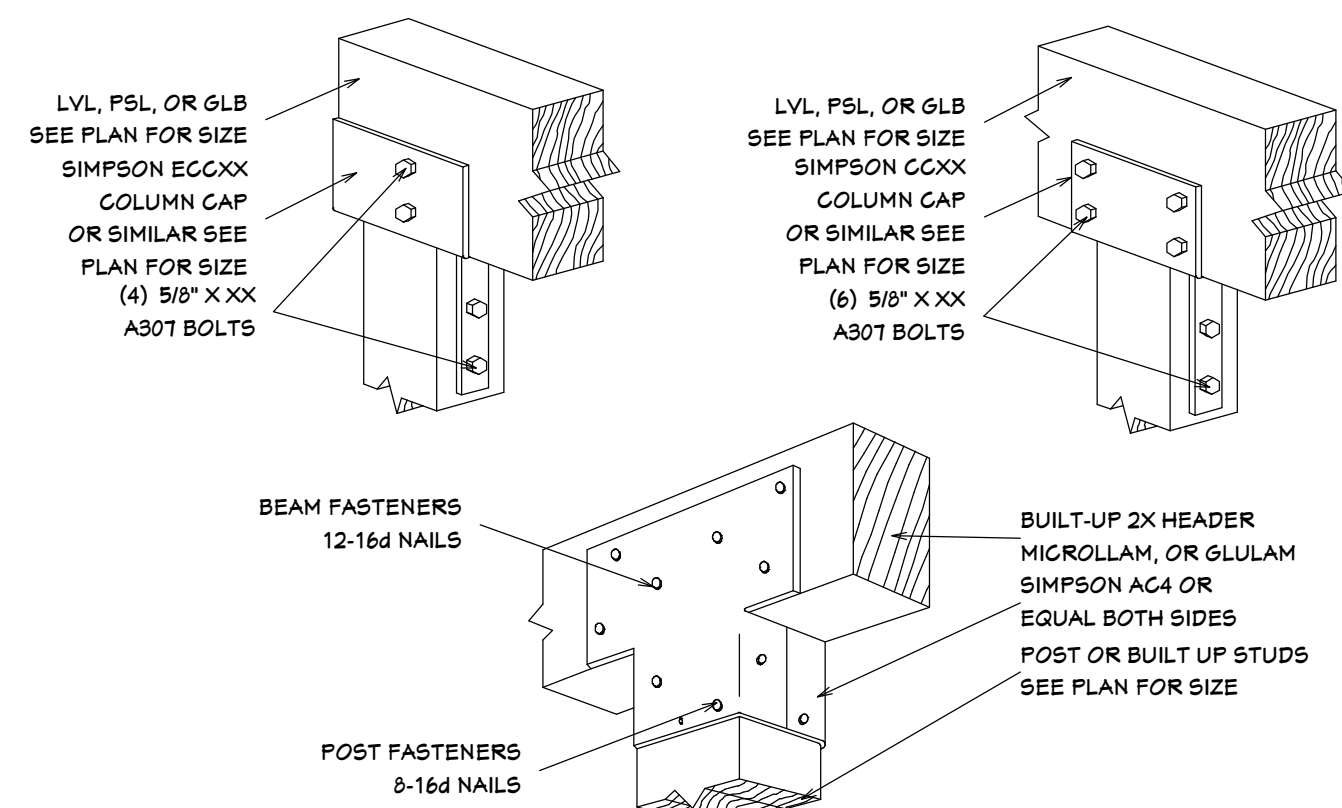

TYPICAL BEAM CONNECTION DETAIL

NOT TO SCALE

16

S7

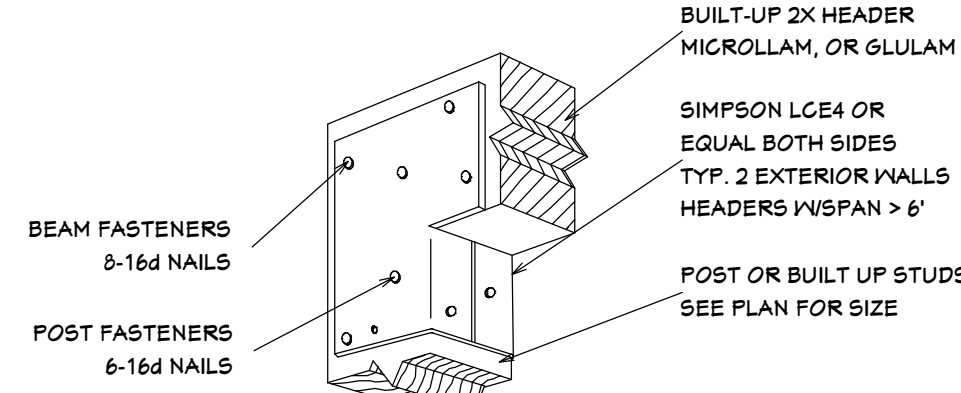

TYPICAL GREATER 6' HEADER DETAIL

NOT TO SCALE

17

S7

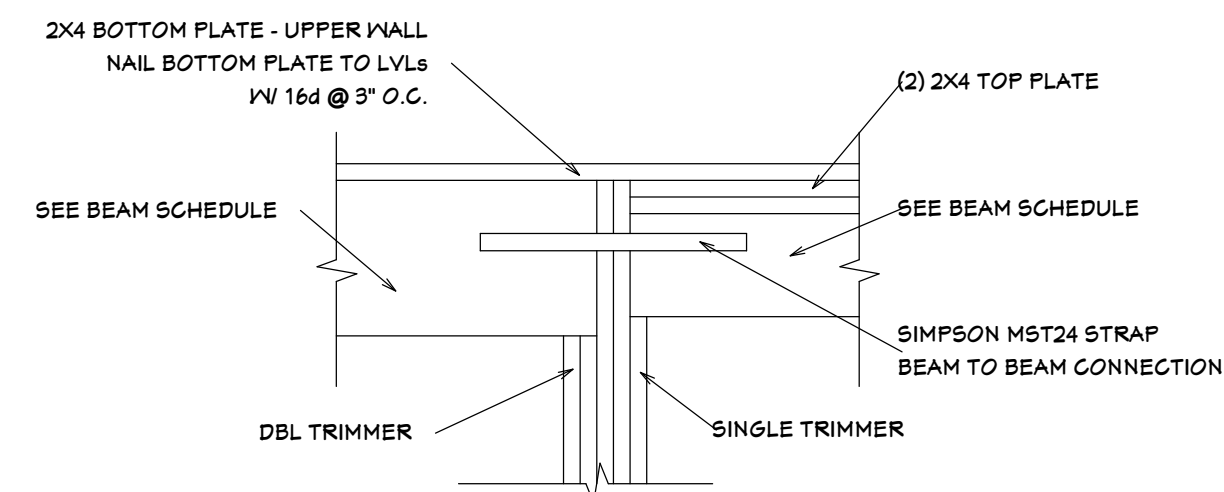

TYPICAL BEAM TO BEAM TIE DETAIL

NOT TO SCALE

18

S7

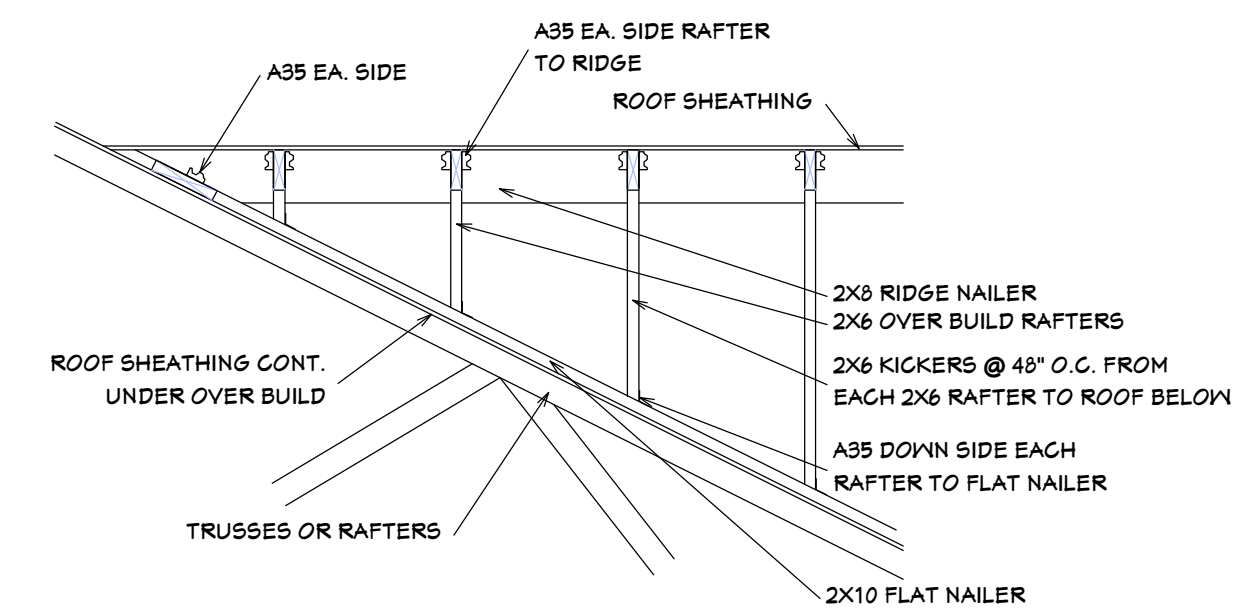

OVERBUILD DETAIL

NOT TO SCALE

19

S7

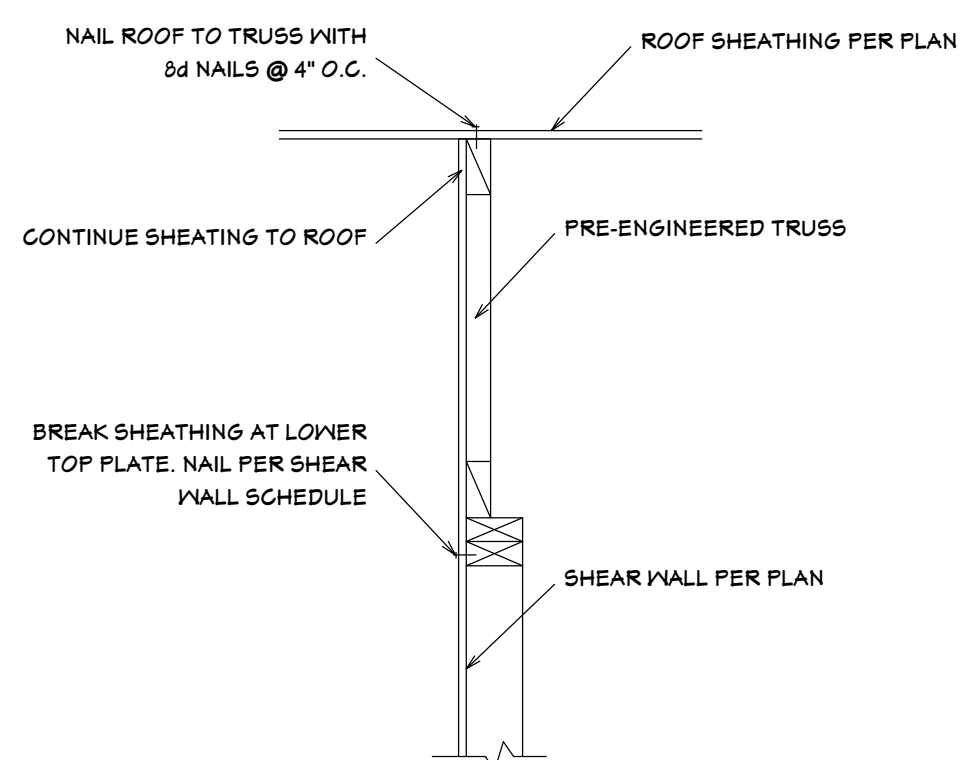

INTERIOR SHEAR WALL CONNECTION

NOT TO SCALE

20

S7

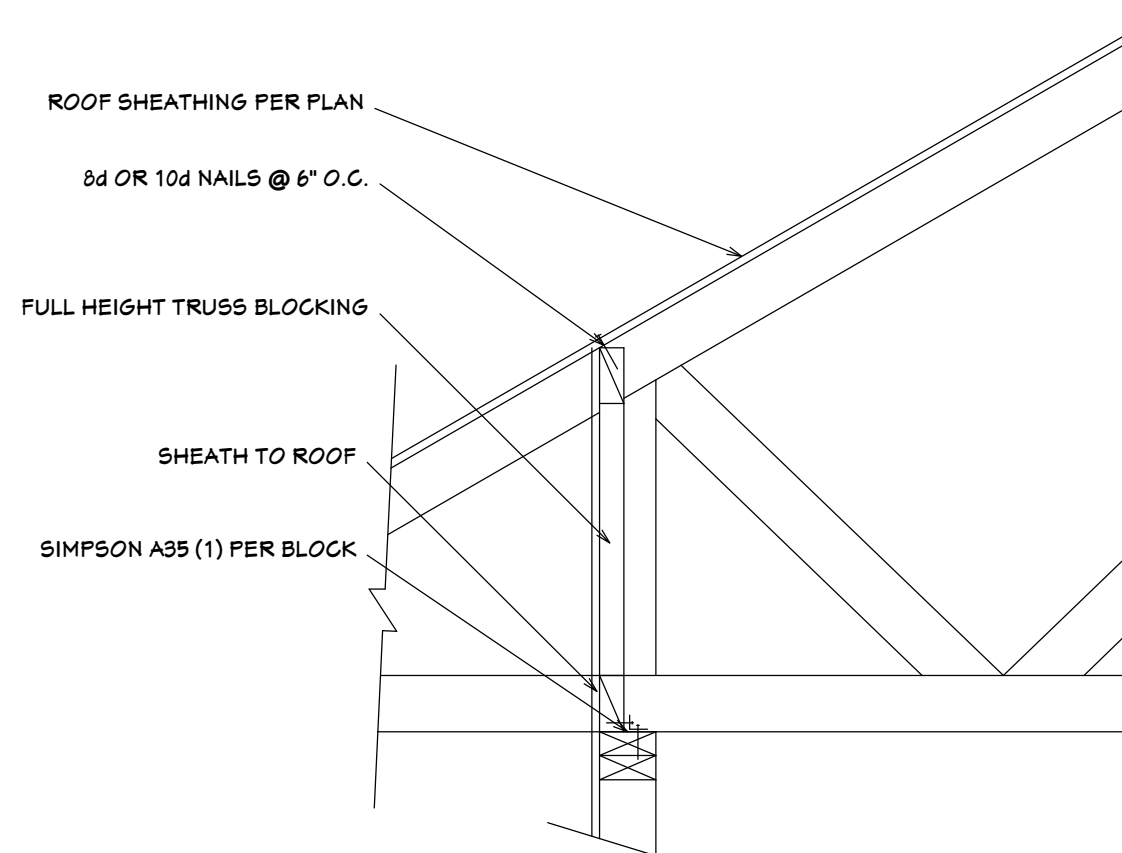

INTERIOR SHEAR WALL CONNECTION

NOT TO SCALE

21

S7

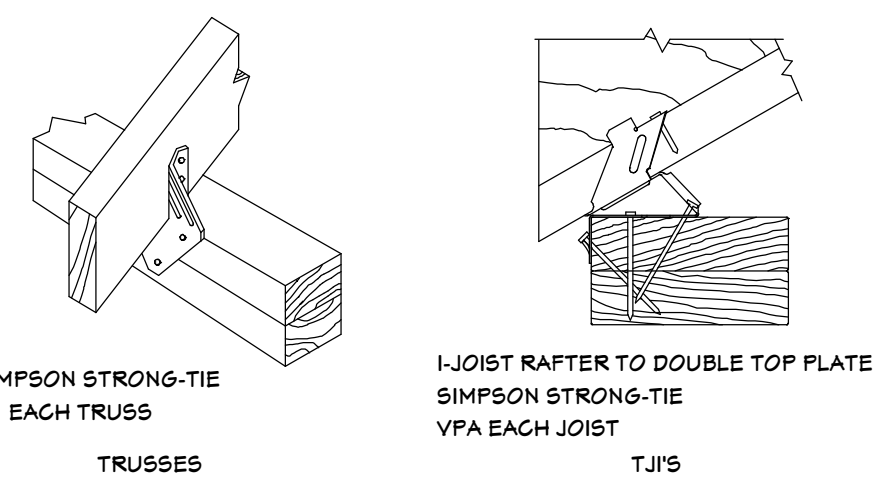

ROOF JOIST CONNECTIONS

NOT TO SCALE

22

S7

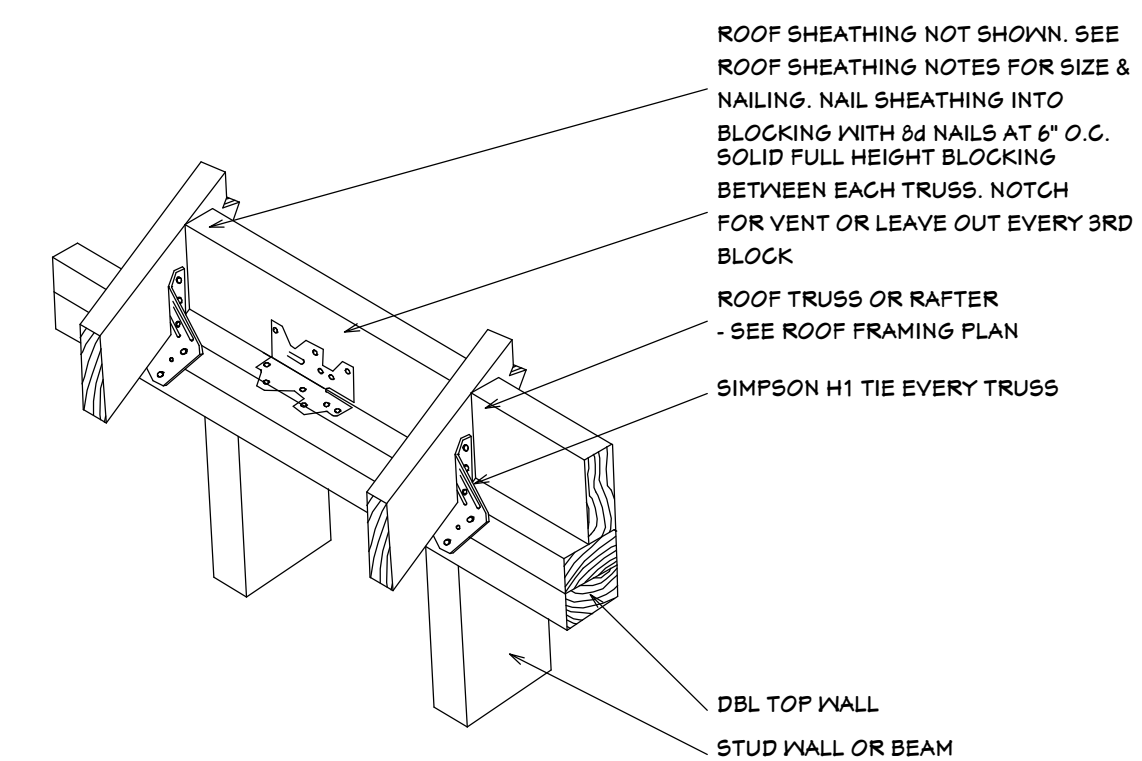

ROOF FRAMING CONNECTION

NOT TO SCALE

23

S7

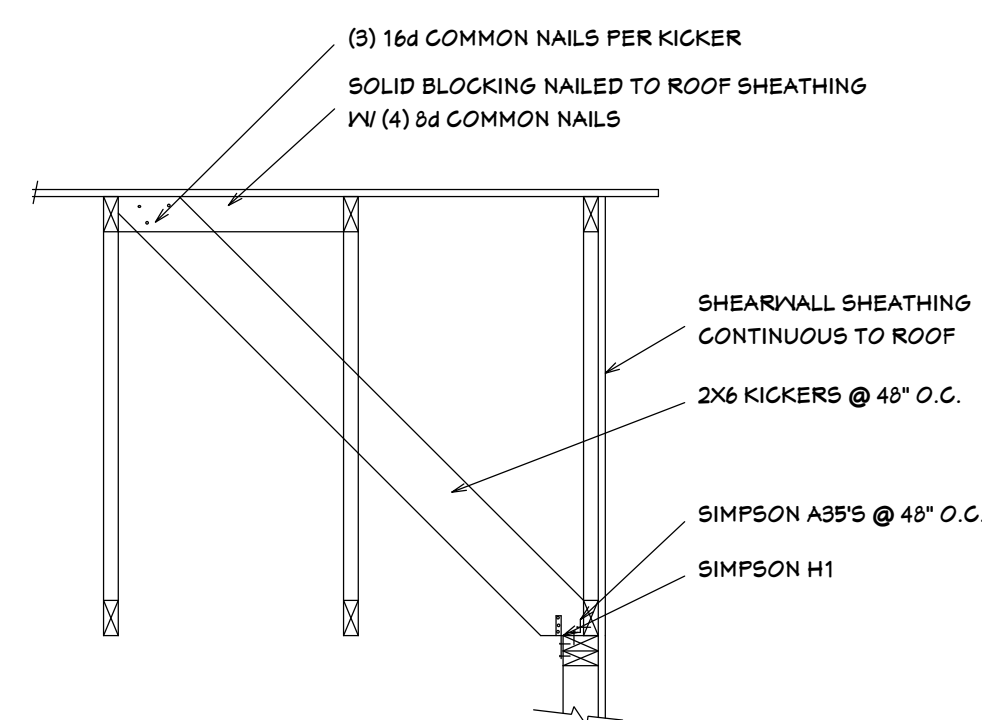

GABLE END DETAIL

NOT TO SCALE

24

S7

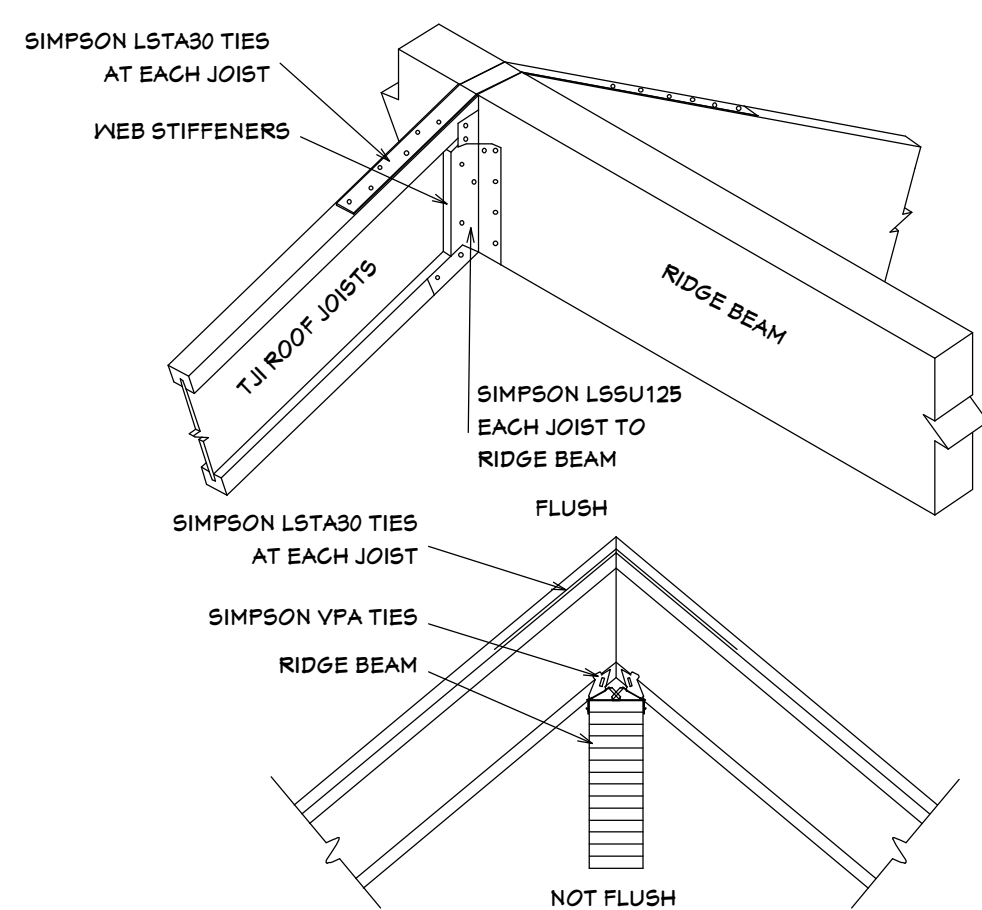

RIDGE DETAILS

NOT TO SCALE

25

S7

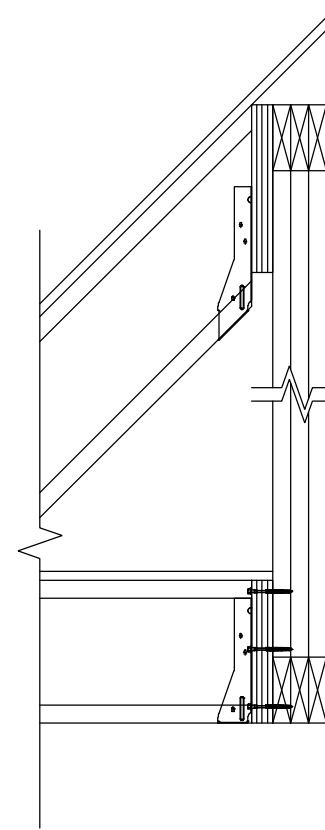

STICK FRAMING TO GIRDER TRUSS

NOT TO SCALE

26

S7

Stamp:
Not
Approved
For
Construction
Without
Engineer
Stamp

SIL VERPEAK
ENGINEERING
177 E ANTELOPE DR. #B
LAYTON, UT 84041
PHONE: (801) 392-4211
FAX: (801) 392-2941

Architectural Design:
Harker Design
5224 South Yellowstone Ave., Idaho Falls, Id
208-523-3322 --- www.harkerdesign.com

Project:
FRAZIER RESIDENCE
Address: Lot 6 Block 2, Water Front Estates, Rigby, Idaho

Structural
Details

Issue Date:
8/17/2017
S7
No Scale